

1 RoHS Compliance

6	7	8
REV	SYM	Revision Record
V0	KLS05036	New Version Release
		Appr. Song
		Date 2024-08-26

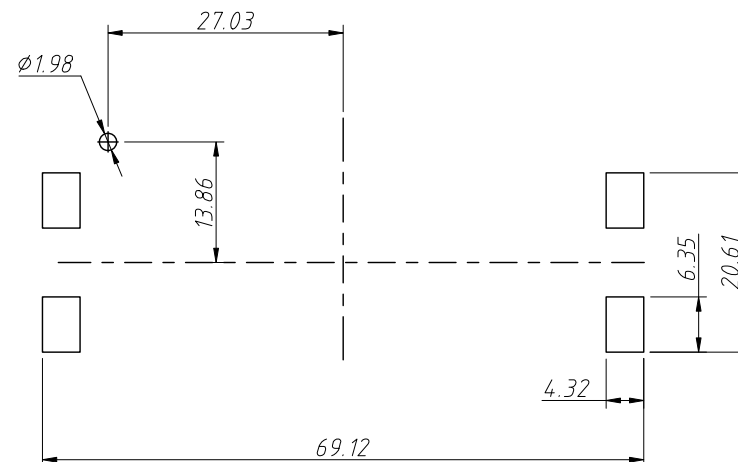
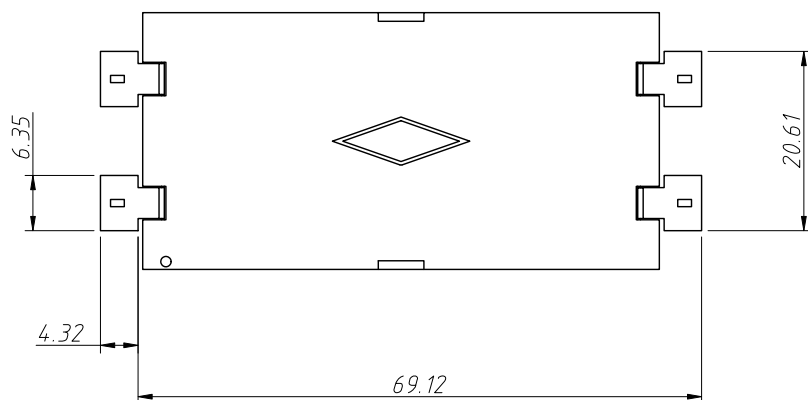
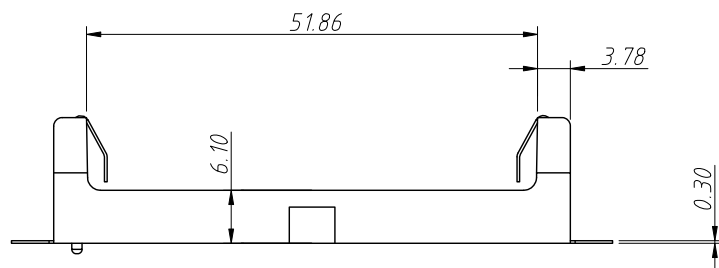
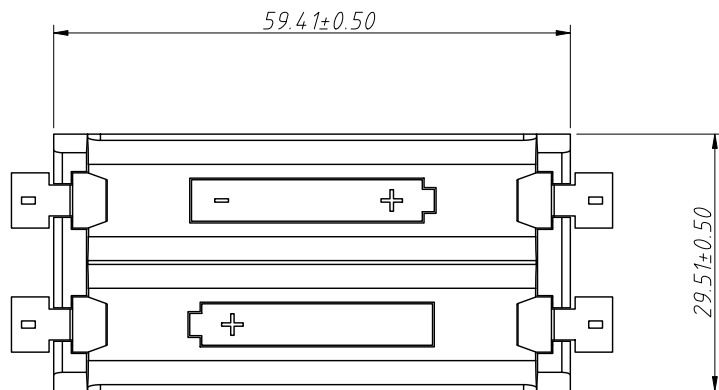
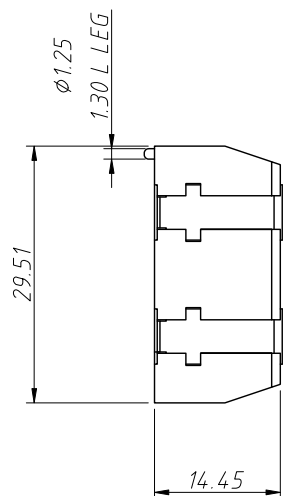

PCB Layout

Note:

- 1.Base Material:Nylon66,UL 94 V-0,Black
- 2.Contacts:0.35mm Phosphor Bronze, Flash Gold
- 3.Heat Deflection Temperature:242°C,1.80Mpa

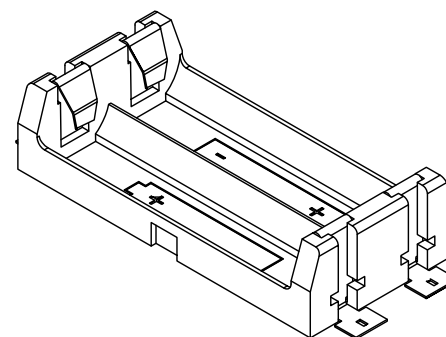

ANGLE TOLERANCE	PROJECTION	Description:	
±3°		TWO"AA"Cells Holder	
GENERAL TOLERANCE	UNITS	mm	KLS P/N: L-KLS5-827-M0
.x ±0.30	SHEET SIZE	A4	NingBo KLS ELECTRONIC CO.,L TD.
.xx ±0.20	Draw:	Song	
.xxx ±0.10	Check:	Daniel	