

MB-1 / MB-1(B) / MB-1N

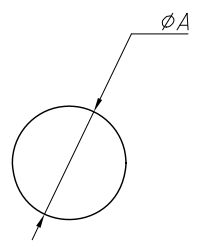

Part No.	Board Thickness	A	B	C	D	Color
L-KLS8-0233-MB-1	2.0~3.1	3.3~3.5	7.6	1.6	8.6	White
L-KLS8-0233-MB-1(B)						Black
L-KLS8-0233-MB-1N						Natural
L-KLS8-0233-MB-2	3.0~4.0	3.3~3.6	7.6	1.3	10.8	White
L-KLS8-0233-MB-2(B)						Black
L-KLS8-0233-MB-2N						Natural
L-KLS8-0233-MB-3N	2.0~3.5	3.0~3.5	7.3	1.4	8.4	Natural
L-KLS8-0233-MB-3N(B)						Black

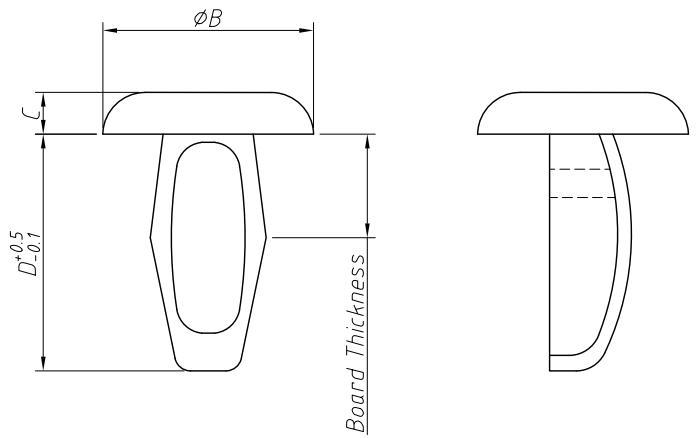

MB-2 / MB-2(B) / MB-2N
MB-3N / MB-3N(B)

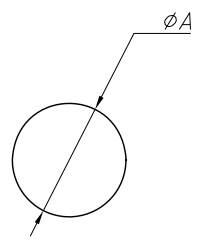

Notes:
Material: POM, UL94V-0
The Color Batch Test Report Is Only For First Lot Test
Shrinking Is Normal Status
Made Of Equivalent Material

ANGLE TOLERANCE	PROJECTION	Description:	Sanp Rivets	
±3°				
GENERAL TOLERANCE	UNITS	mm	KLS P/N:	L-KLS8-0233-MB-XX
.x ±0.30	SHEET SIZE	A4		
.xx ±0.20	Draw:	WuHao	2025-02-22	NingBo KLS ELECTRONIC CO.,L TD.
.xxx ±0.10	Check:	Daniel	2025-02-22	