

RoHS Compliance

REV	SYM	Revision Record	Appr.	Date
V0	KLS07008	New Version Release	WuHao	2025-02-11

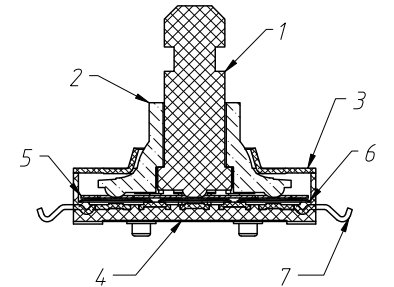
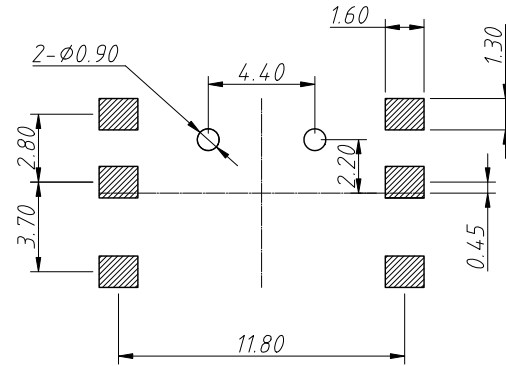
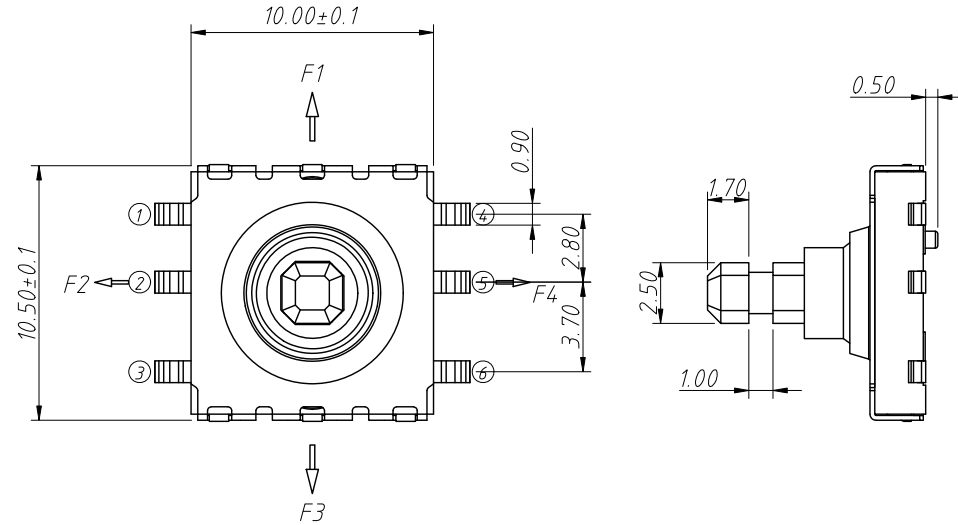

Recommended PCB Layout
Tolerance: ±0.05mm

	①	②	③	④	⑤	⑥
F1	○			○		
F2	○	○				
F3	○					○
F4	○			○		
F5	○	○				

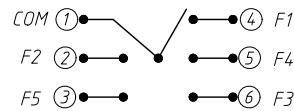

Circuit Diagram ■

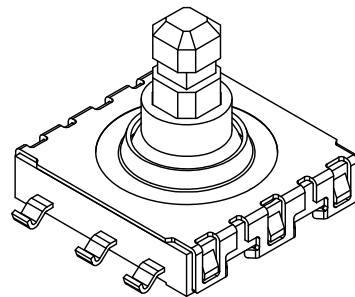
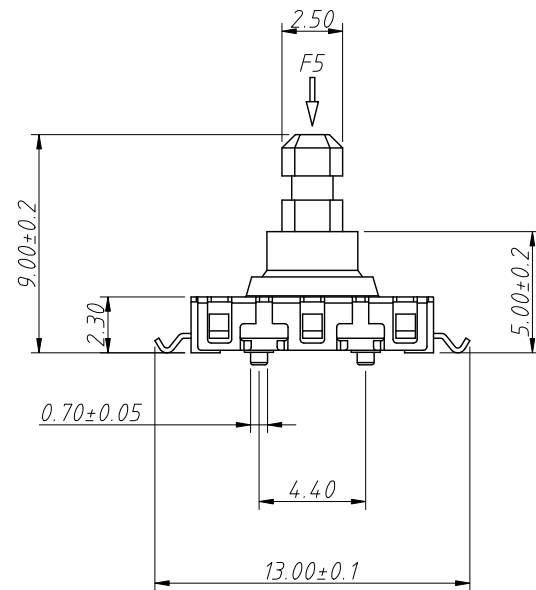

Electrical Characteristics:
 Current rating: 50mA Max
 Voltage rating: DC 12V
 Contact resistance: 80mΩ Max
 Insulation resistance: 100MΩ Min (DC 100V)
 Dielectric strength: AC 250V 50Hz/1 min
 Operating force: 250gf ± 50gf
 Mechanical life: 50000 cycles
 Operation Stroke: 0.2 ± 0.05mm
 Temperature range: -30°C To +85°C

Material:

1. Button: PA46, Black
2. Plum Sheath: LCP, Ash Black
3. Cover Plate: SUS304, Clean, White
4. Base: PA10T, Black
5. Contact Gasket: Silver Copper, Silver White Silver Plating
6. Shard: Silver Clad Stainless Steel, Silver White Silver Plating
7. Insert: Phosphor Bronze, Silver Inlaid, Silver White

ANGLE TOLERANCE	PROJECTION	Description:	Multi Function Switch	
±3°				
GENERAL TOLERANCE	UNITS	mm	KLS P/N:	L-KLS7-MT-05-9.0-REEL
.x ±0.20	SHEET SIZE	A4	1 OF 2	
.xx ±0.10	Draw:	WuHao	2025-02-11	
.xxx ±0.05	Check:	Daniel	2025-02-11	

NingBo KLS ELECTRONIC CO.,LTD.

1
RoHS Compliance

2	3	4	5	6	7	8
REV	SYM	Revision Record		Appr.	Date	
V0	KLS07008	New Version Release		Song	2025-02-17	

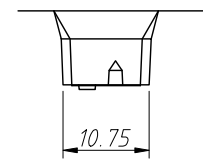
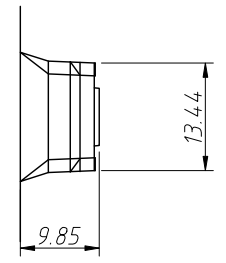
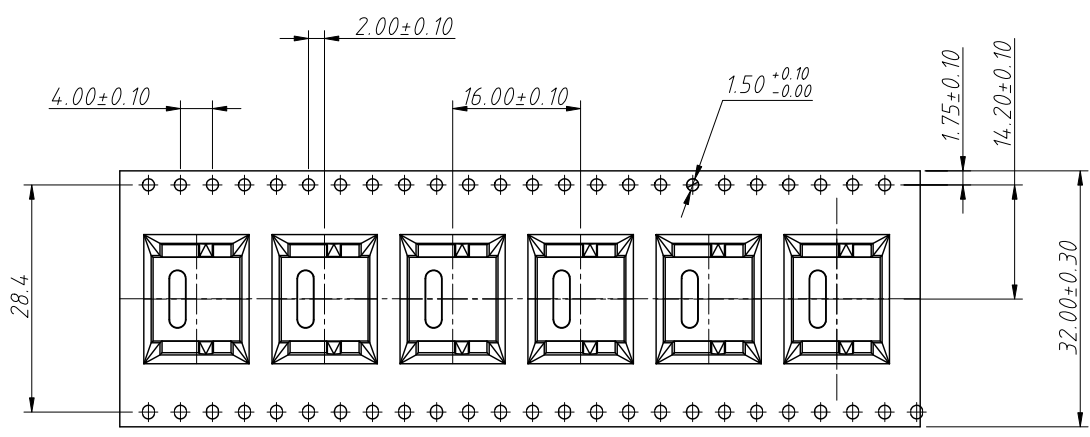
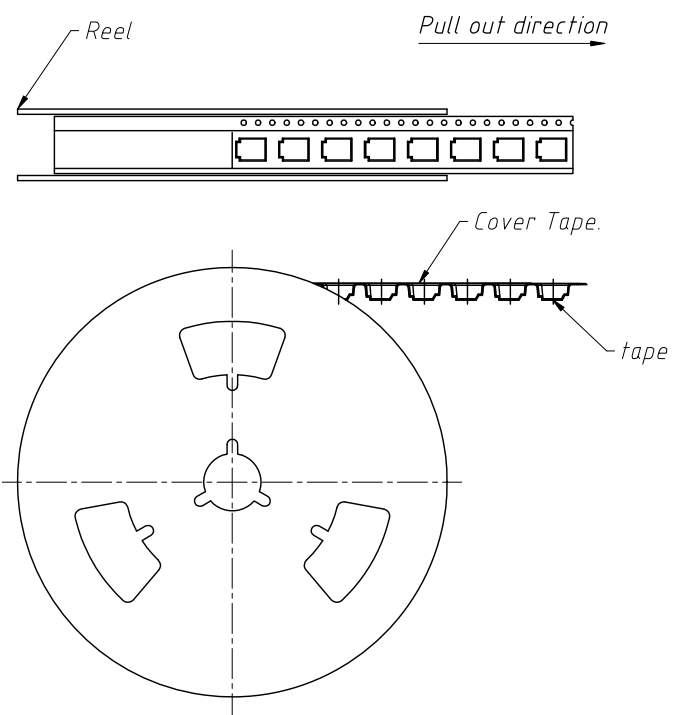

The maximum curvature of the carrier tape within a length of 250mm shall not exceed 1mm

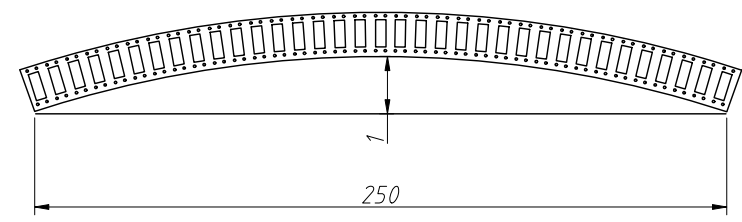

Notes:

1. The cumulative tolerance of 10 edge holes cannot exceed $\pm 0.2\text{mm}$,
2. Material specification: PS transparent anti-static, thickness 0.40mm
3. The total number of 13-inch roller packaging parts is 436 pieces (18 empty pieces in the front section, actual number of packaged parts: 400 pieces, 18 empty pieces in the rear section),

ANGLE TOLERANCE	PROJECTION	Description:			
$\pm 3^\circ$		Multi Function Switch			
GENERAL TOLERANCE	UNITS	mm	KLS P/N:	L-KLS7-MT-05-9.0-REEL	
.x ± 0.20	SHEET SIZE	A4	2 OF 2	NingBo KLS ELECTRONIC CO.,L TD.	
.xx ± 0.10	Draw:	Song	2025-02-17		
.xxx ± 0.05	Check:	Daniel	2025-02-17		