

Switch

Tact Switch Series

KLS7-TS3606B 3x6 Tact Switch Series

ELECTRICAL

1. Rating: 50mA 12VDC
2. Contact Resistance : 50mΩ max(initial)
3. Insulation Resistance: 100MΩ(minDC 250V)
4. Dielectric Strength : AC250V(50/60Hz for 1minute)
5. Electrically Life: 50000cycles
6. Environment temperature: -25°C~+70°C
7. Operating Force: 180/250(±30gf)
8. Seal temperature: 260°C~ 280°C

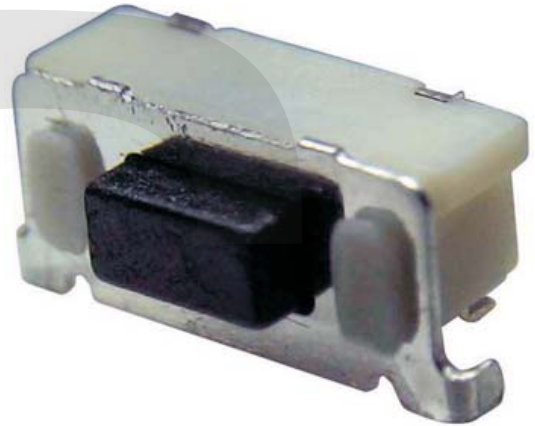

Dimension (unit: mm)

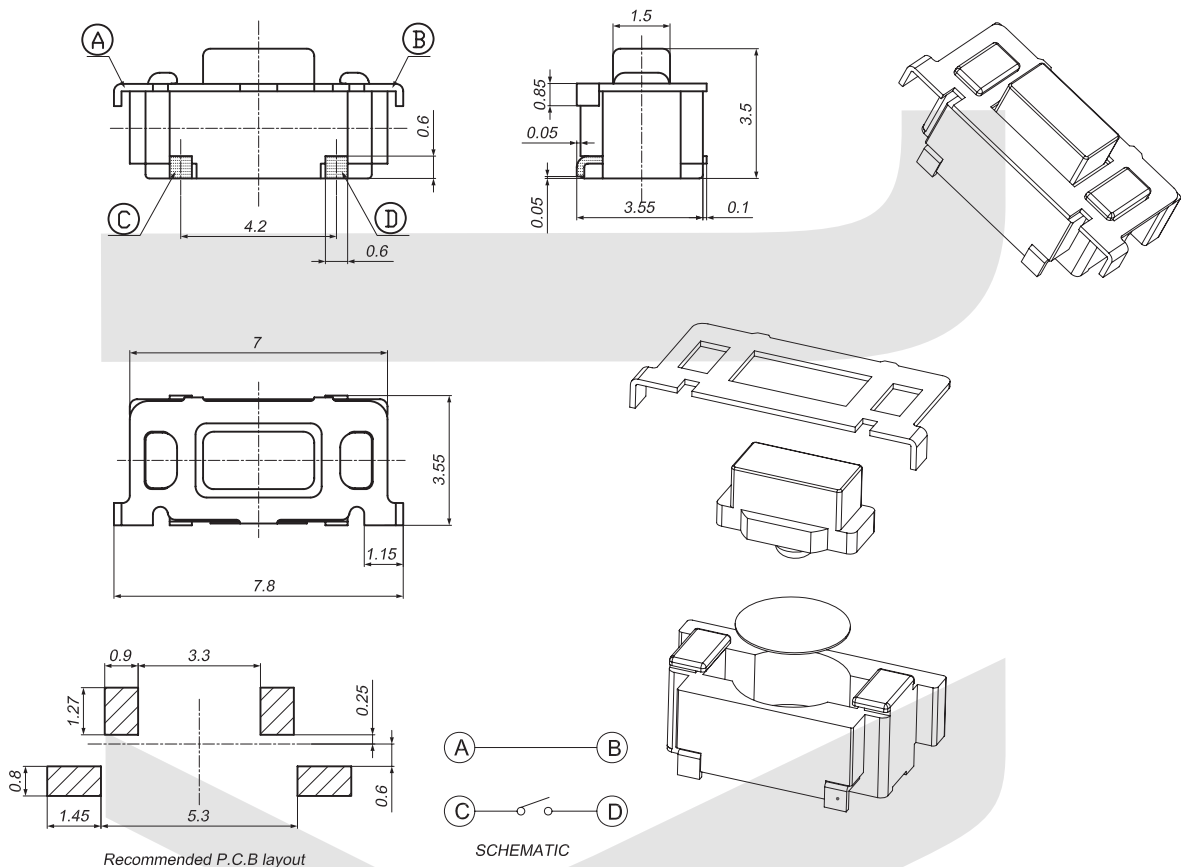

ORDER INFORMATION

KLS7-TS3606B - 3.5 - 180 -B

Series No. _____ Packing: B=Bulk T=Tape
 Height: 3.5mm _____ Operating Force : 180~250gf

1 RoHS Compliance

6	7	8		
REV	SYM	Revision Record	Appr.	Date
V0	KLS07047	New Version Release	WuHao	2025-01-16

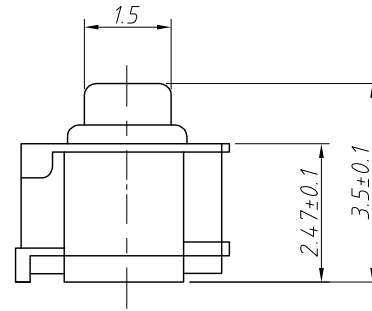
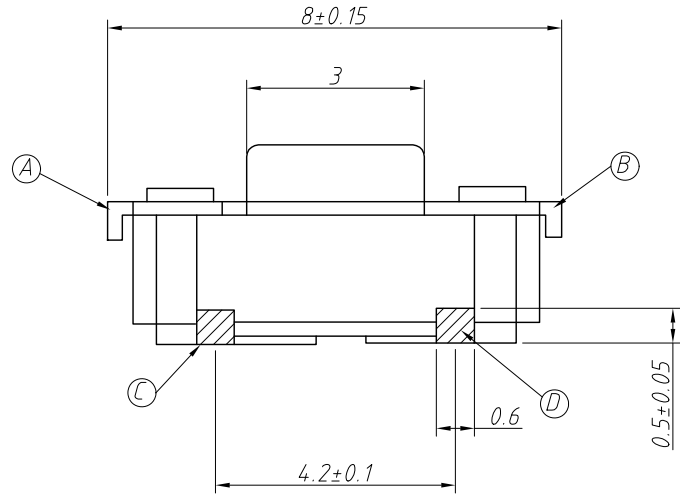

Material:

- 1.Inserts:Brass,Silver Plating
- 2.Base:PPA,Black
- 3.Spring:Imported Stainless Steel
- 4.Skullcap:PPA,Black
- 5.Cover Plate:Brass,Silver Plating

Electric:

- Rating:50mA 12V DC
 Travel:0.20±0.1mm
 Contact Resistance :100mΩ Max
 Operating Force:180g/250g±50g
 Life:50000 Cycles Min

Order Information:

L-KLS7-TS3606B-3.5-180-T

- L: RoHS
 Tact Switch
 Height:3.5mm
 Operating Force:
 180g±50g 250g±50g
 Packing:T=Tape

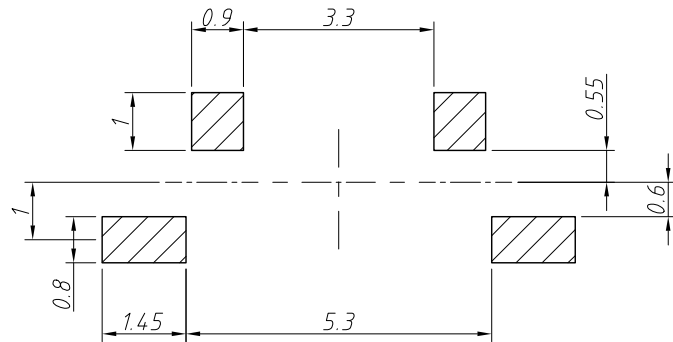
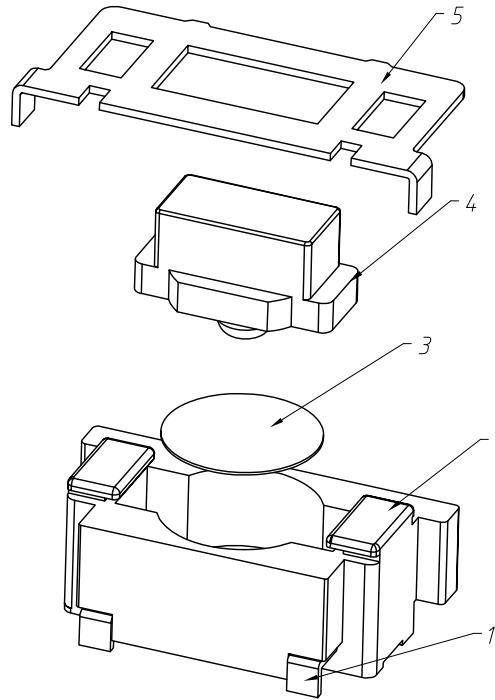
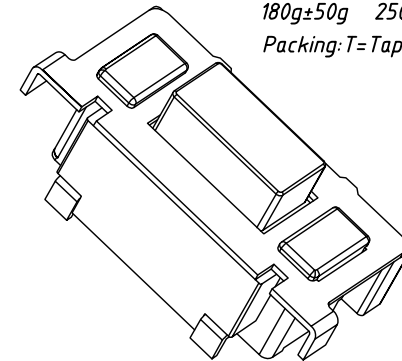

Recommended PCB Layout

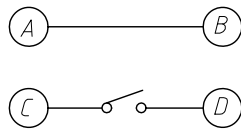

Schematic

ANGLE TOLERANCE	PROJECTION	Description:		
±3°		Tact Switch		
GENERAL TOLERANCE	UNITS	mm	KLS P/N:	L-KLS7-TS3606B-3.5-XXX-T
.x ±0.30	SHEET SIZE	A4		
.xx ±0.20	Draw:	WuHao	2025-01-16	NingBo KLS ELECTRONIC CO.,L TD.
.xxx ±0.10	Check:	Daniel	2025-01-16	