

PCB LAYOUT

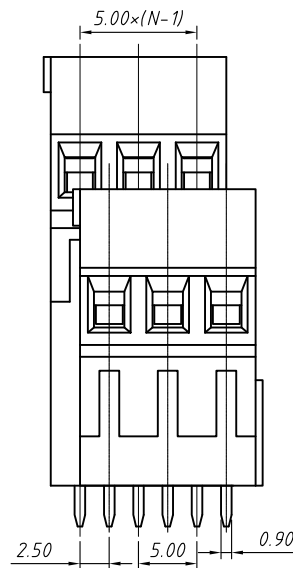
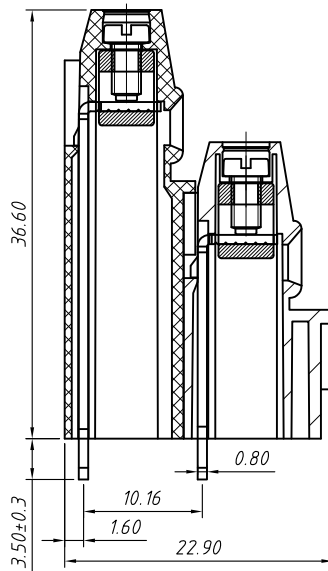
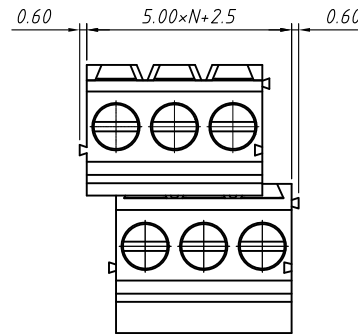

Material
Housing: PA66, UL94V-0
Pin header: Brass, Tin plated
Clamp: Brass, Ni plated
Screw: M2.5, steel Zinc plated

Electrical
Rated voltage: 300V
Rated current: 15A
Contact Resistance: 20 mΩ
Insulation resistance: 500MΩ/DC500V
Withstand voltage: AC2000V / 1 min
Wire Range: 30~14AWG 2.5mm²

Mechanical
Temp. Range: -40 °C ~ +105 °C
Strip length: 6~7mm
Torque: 0.4Nm (3.5Lb.in)

Order Information

L-KLS2-128A2-5.00-XXP-4 S 00

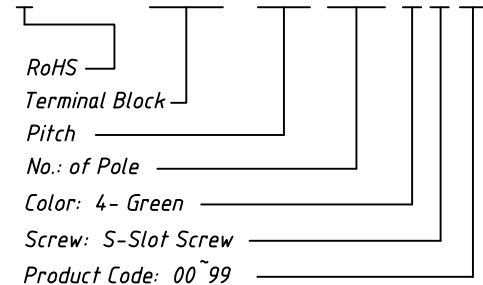

| GENERAL TOLERANCE | | ANGLE TOLERANCE | | Description: | |
|-------------------|------------|-----------------|----|---------------------------------|------------------------|
| X. ±0.60 | | X. ±5° | | Screw CONN TERM Block 5.00mm | |
| .X ±0.38 | | .X ±3° | | KLS P/N: | KLS2-128A2-5.00-XXP-4S |
| .XX ±0.25 | | .XX ±2° | | | |
| Draw by | 2015-09-01 | PROJECTION | | NingBo KLS ELECTRONIC CO.,L TD. | |
| Check by | 2015-09-15 | UNITS | mm | | |
| SCALE | | SHEET SIZE | A4 | | |

1 RoHS Compliance

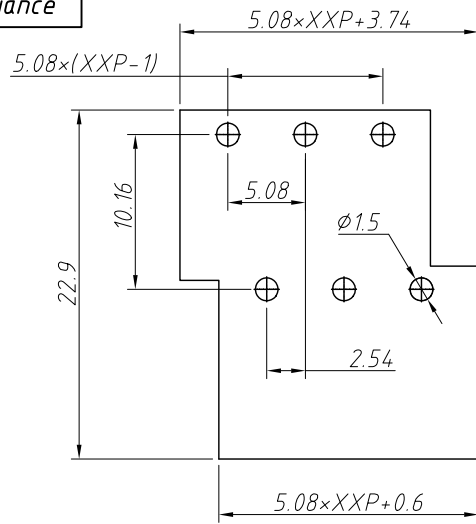

Recommended PCB Layout

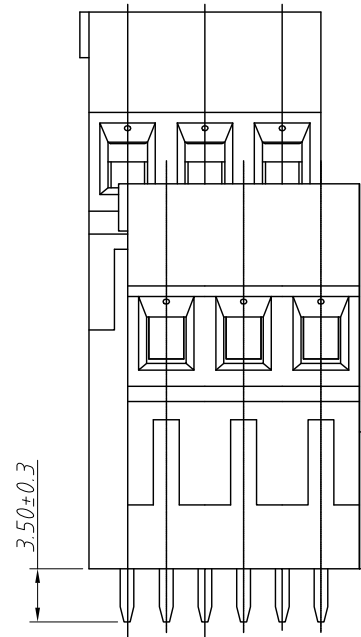
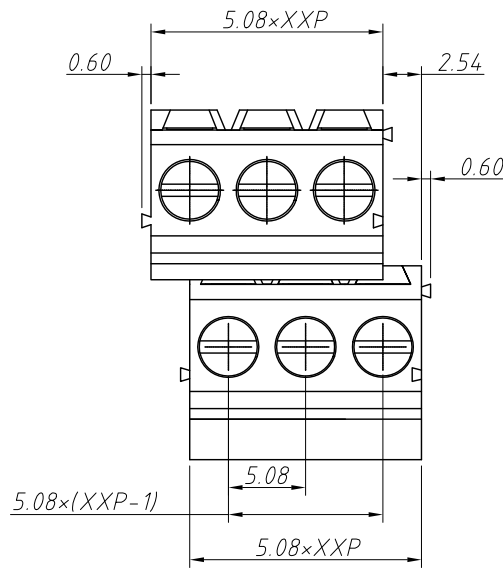
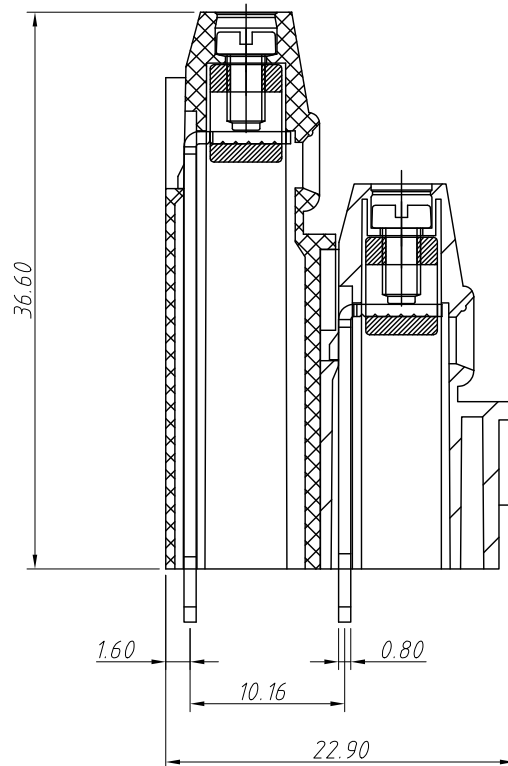

| | | |
|-----|----------|---------------------|
| 6 | 7 | 8 |
| REV | SYM | Revision Record |
| VO | KLS02006 | New Version Release |
| | | Appr. Song |
| | | Date 2024-11-12 |

| | | |
|-------------------|---------------|---------------------|
| Electrical | UL | IEC |
| Rated Voltage | 300V | 250V |
| Rated Current | 15A | 17.5A |
| Withstand Voltage | AC2000V/1 min | --- |
| Wire Range | 30~14 AWG | 1.5 mm ² |

Material and other:
 Housing:PA66, UL94V-0
 Pin Header:Brass,Tin Plated
 Cage:Brass,Ni Plated
 Screw/Torque:Steel,Zn Plated,M2.5/0.4N.m
 Contact Resistance:20mΩ Max
 Insulation Resistance:500MΩ/DC500V Min
 Stripping Length:6-7mm
 Temp. Range:-40°C ~ +105°C
 MAX Soldering:250°C For 5S

Order Information

L-KLS2-128A2-5.08-XXP-X X

RoHS
 Terminal Block
 Pitch:5.08mm
 No.:Of (2x02~2x24) Pin
 Color:
 1=Gray 2=Blue 3=Black
 4=Green 5=Orange 6=Red
 7=Transp 8=Yellow 9=White
 Screw:SC=Slot/Cross
 S-Slot Screw C-Cross Screw

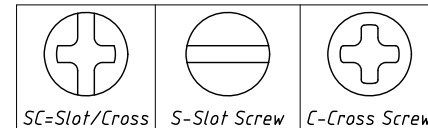

| | | |
|-------------------|---------------|-----------------------------|
| ANGLE TOLERANCE | PROJECTION | Description: |
| ±3° | | Pitch 5.08mm Terminal Block |
| GENERAL TOLERANCE | UNITS | KLS P/N: |
| 0~30 ±0.50 | mm | L-KLS2-128A2-5.08-XXP-XX |
| 30~60 ±0.75 | SHEET SIZE | Draw: Song |
| 60~90 ±1.00 | A4 | 2024-11-12 |
| | Check: Daniel | 2024-11-12 |



NingBo KLS ELECTRONIC CO.,L TD.