

1
RoHS Compliance

6		7		8	
REV	SYM	Revision Record	Appr.	Date	
V0	KLS02006	New Version Release	WuHao	2024-11-12	

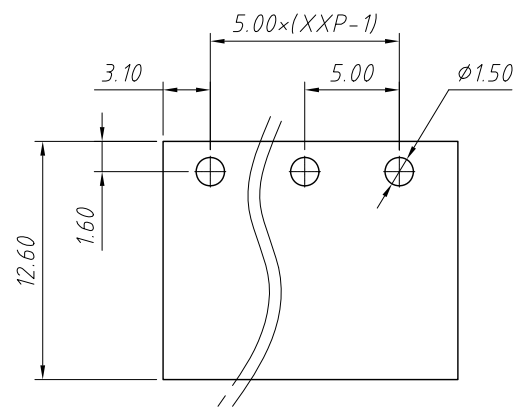

Recommended PCB Layout

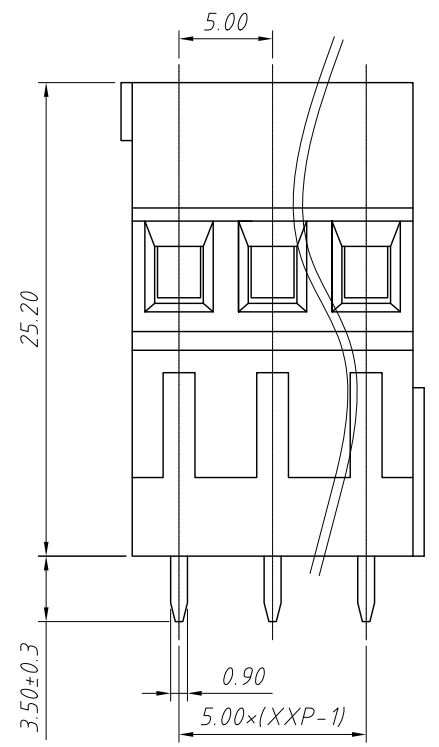
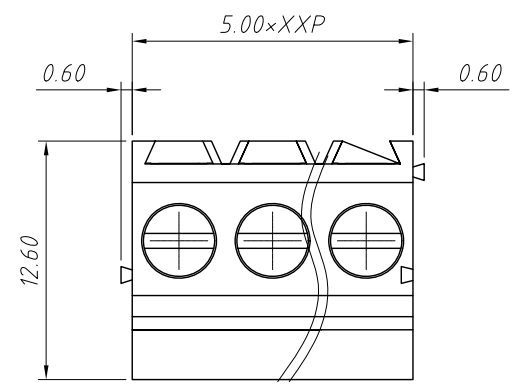
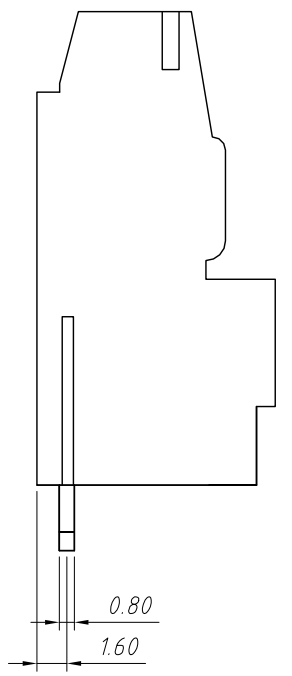

Electrical Characteristics	UL	IEC
Rated Voltage	300V	250V
Rated Current	15A	24A
Withstand Voltage	1600V/1 min	4.0 KV
Wire Range	30~14 AWG	0.5~2.5mm ²

Material
 Housing: PA66, UL94V-0
 Pin Header: Copper alloy, Sn plated
 Steip Length: 6~7 mm
 Screw/Torque: M2.5/0.4N.m Max
 Operating Temperature: -40°C ~ +105°C
 Soldering Temperature: +260°C, For 5 Sec
Order Information

L-KLS2-128IH-5.00-XXP-X X 01

RoHS
 Terminal Block
 Pitch: 5.00mm
 No. of (02~24) Pole
 Color:
 1=Gray 2=Blue 3=Black
 4=Green 5=Orange 6=Red
 7=Transp 8=Yellow 9=White
 Screw: SC=Slot/Cross
 S-Slot Screw C-Cross Screw

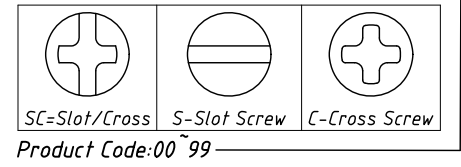

ANGLE TOLERANCE	PROJECTION	Description:			
±3°		Pitch 5.00mm Terminal Blocks			
GENERAL TOLERANCE	UNITS	mm	KLS P/N:	L-KLS2-128IH-5.00-XXP-XX01	
x.x ±0.30	SHEET SIZE	A4		NingBo KLS ELECTRONIC CO.,L TD.	
x.xx ±0.20	Draw:	WuHao	2024-11-12		
x.xxx ±0.10	Check:	Daniel	2024-11-12		

1 RoHS Compliance

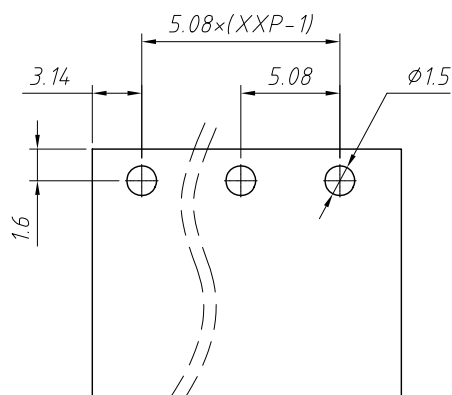

Recommended PCB Layout

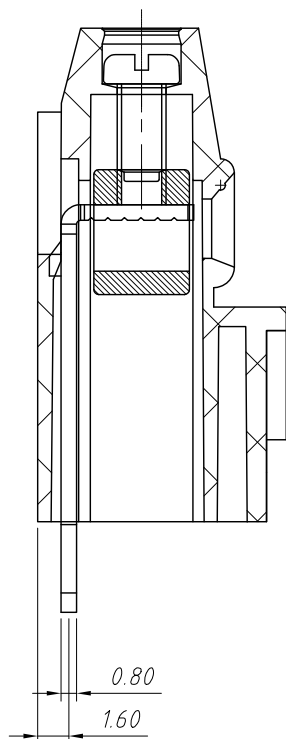

SECTION A-A

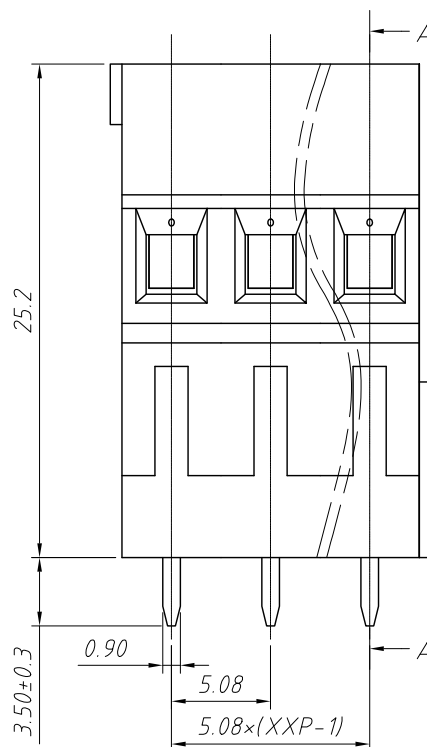
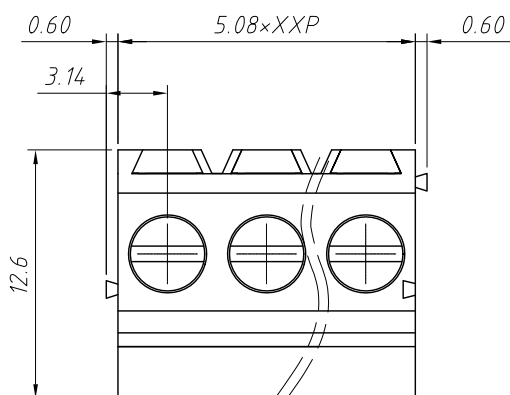

REV	SYM	Revision Record	Appr.	Date
V0	KLS02006	New Version Release	WuHao	2024-11-11

Electrical Characteristics	UL	IEC
Rated Voltage	300V	250V
Rated Current	15A	17.5A
Withstand Voltage	AC2000V/1min	---
Wire Range	30~14 AWG	1.5mm ²

Material

Housing:PA66,UL94V-0 Pin Header:Copper alloy,Sn plated

Cage:Copper alloy,Ni plated Steip Length:6~7 mm

Screw/Torque:Steel,M2.5,Zn Plated/0.4N.m Max

Temp. Range:-40°C ~ + 105°C Soldering:+250°C,For 5 Sec

Contact resistance:20mΩ MAX Insulation resistance:500MΩ/DC500V

Order Information

L-KLS2-128IH-5.08-XXP-X X 01

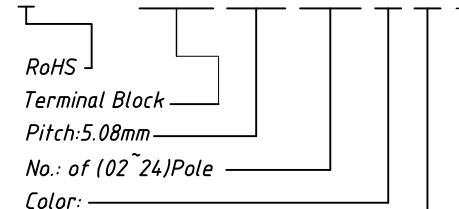

RoHS

Terminal Block

Pitch:5.08mm

No. of (02~24)Pole

Color:

1=Gray 2=Blue 3=Black

4=Green 5=Orange 6=Red

7=Transp 8=Yellow 9=White

Screw:SC=Slot/Cross

S-Slot Screw C-Cross Screw

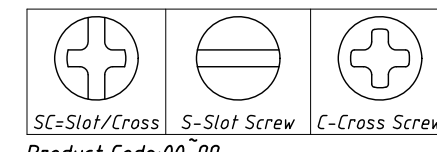

Product Code:00~99

ANGLE TOLERANCE	PROJECTION	Description:
±3°		Pitch 5.08mm Terminal Blocks
GENERAL TOLERANCE	UNITS	mm
x.x ±0.30	SHEET SIZE	A4
x.xx ±0.20	Draw:	WuHao 2024-11-11
x.xxx ±0.10	Check:	Daniel 2024-11-11
KLS ELECTRONIC		NingBo KLS ELECTRONIC CO.,L TD.