

1
RoHS Compliance

6		7		8	
REV	SYM	Revision Record		Appr.	Date
V0	KLS07029	New Version Release		Song	2024-12-05

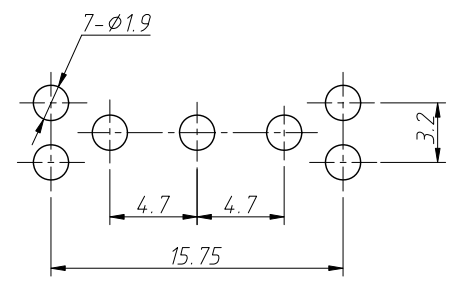
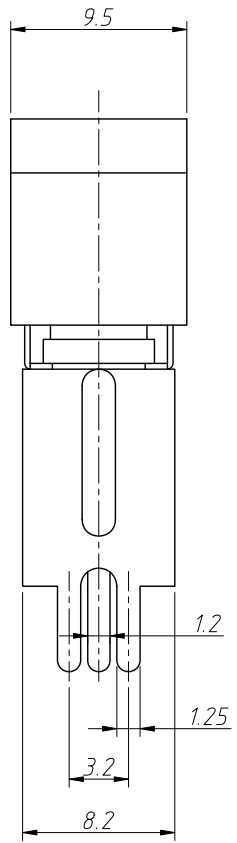
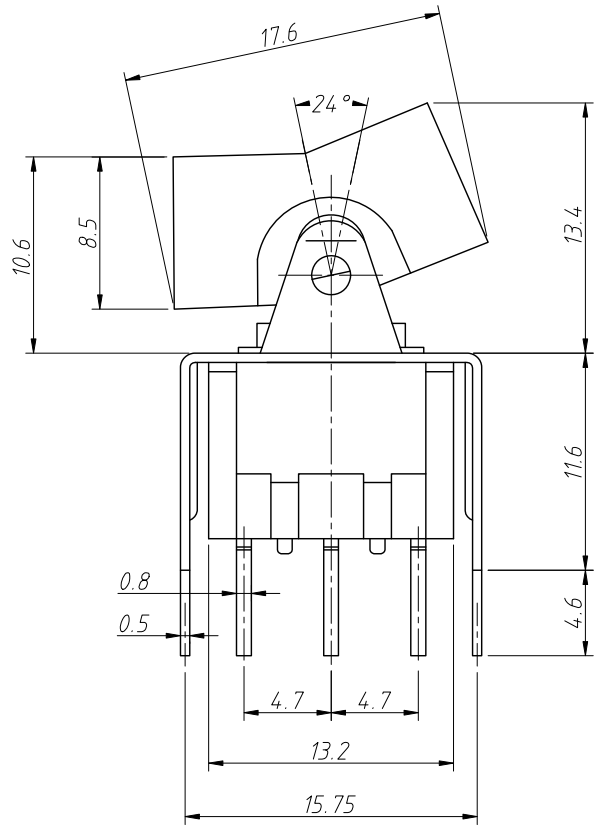

Mounting

Notes:
 Rating: 6A 125V AC: 3A 250V AC
 Contact Resistance: 20 mΩ Max
 Insulator Resistance: 1000 MΩ Min At 500V DC
 Dielectric Strength: 1 Minute 1500V AC
 Operating Temperature: -25°C ~ +85°C
 Electrical Life: 10000 Cycles

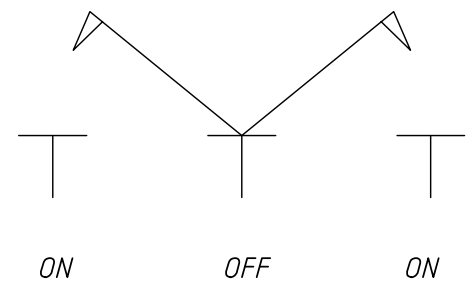

Circuitry

ANGLE TOLERANCE		PROJECTION		Description:	
±3°				Miniature Rocker And Lever Handle Switches	
GENERAL TOLERANCE		UNITS	mm	KLS P/N:	
.x	±0.30	SHEET SIZE	A4	L-KLS7-RLS-103-A2T	
.xx	±0.20	Draw:	Song	2024-12-05	
.xxx	±0.10	Check:	Daniel	2024-12-05	

KLS NingBo KLS ELECTRONIC CO.,LTD.