

1  
RoHS Compliance

6	7	8
REV	SYM	Revision Record
V0	KLS07029	New Version Release
		Appr. Song
		Date 2024-12-05

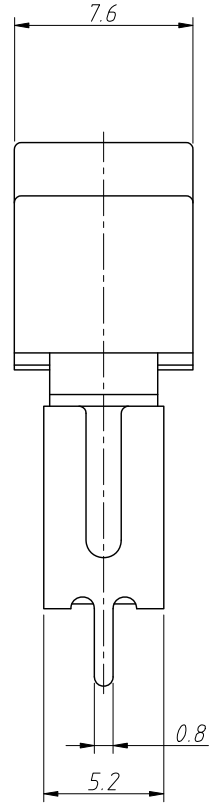

Notes:  
 Rating: 3A 125V AC, 1.5A 250V AC  
 Contact Resistance: 20 mΩ Max  
 Insulator Resistance: 1000 MΩ Min At 500V DC  
 Dielectric Strength: 1 Minute 1000V AC  
 Operating Temperature: -25°C ~ +85°C  
 Electrical Life: 10000 Cycles

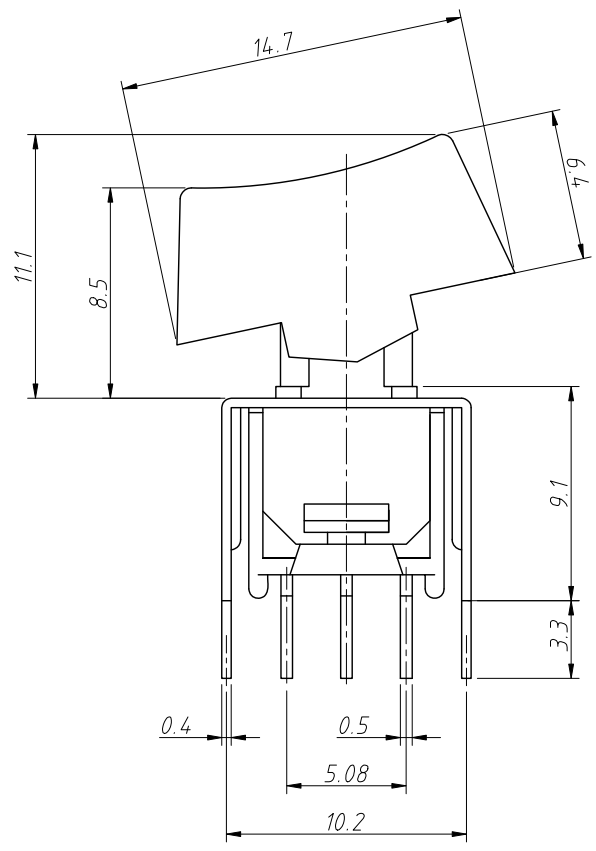
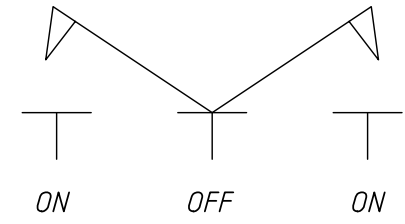

Circuitry

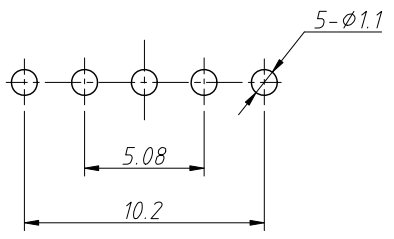

Mounting

ANGLE TOLERANCE	PROJECTION	Description:
±3°		Sub-Miniature Rocker And Lever Switches
GENERAL TOLERANCE	UNITS	mm
.x ±0.30	SHEET SIZE	A4
.xx ±0.20	Draw:	Song
.xxx ±0.10	Check:	Daniel
		KLS P/N: L-KLS7-SRLS-103-A2T
		NingBo KLS ELECTRONIC CO.,LTD.