

1 RoHS Compliance

6	7	8		
REV	SYM	Revision Record	Appr.	Date
V0	KLS17048	New Version Release	Song	2024-11-22

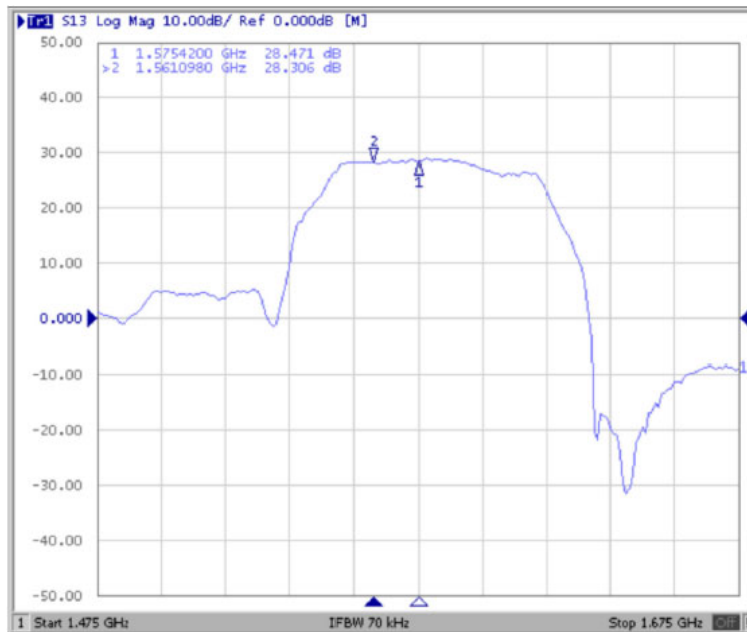

Notes:  
 Frequency Range:GPS1575.42±1MHz  
 Band Width:±5MHz Typ  
 Axial ratio:≤4DB  
 Vswr:1.5:1  
 Gain:Dielectric 4DB LNA 28DB  
 Impedance:50 OHM  
 Polarization:RHCP  
 Noise Figure:1.5 DB  
 DC Voltage:3-5V  
 DC Current:≤25mA  
 Boundary Dimension:43×36×14.3  
 Cable:RG174-3000MM  
 Connector:SMAJ  
 Working Temp:-40°~80°  
 Way To Install:Magnet  
 Waterproof grade:IP67

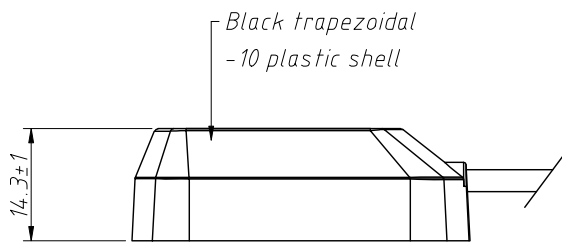

8x2 Single-Sided Magnetic GPS Sticker

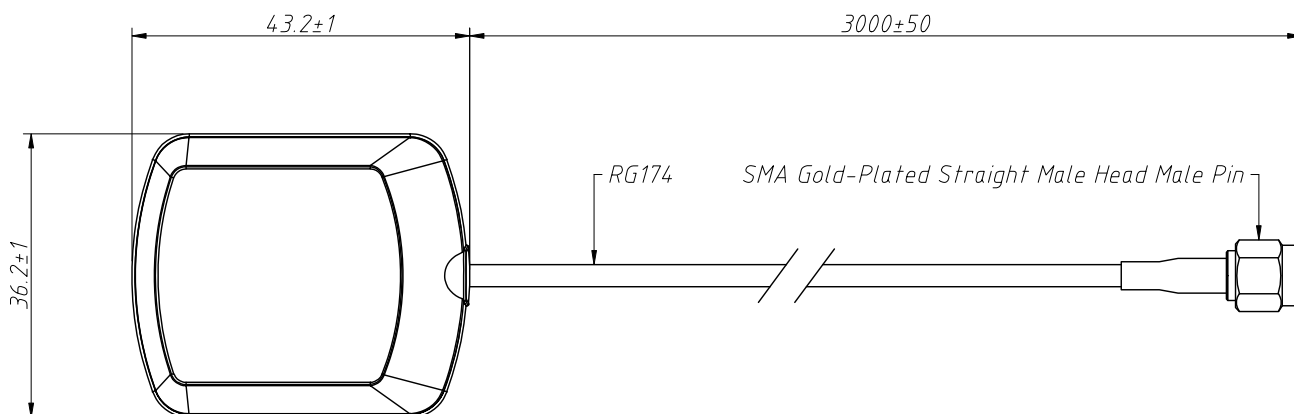

The Assembly Of Each Component Should Be Firm And Reliable  
 The Signal Parameters Of The Finished Product Must Reach  
 The Specified Value  
 The Product Needs To Be Packaged In Quantity According To  
 The Requirements, And There Should Be No Obvious Signs  
 During Transportation Phenomena Such As Compression  
 Deformation

ANGLE TOLERANCE	PROJECTION	Description:	GPS Active Antenna	
±3°				
GENERAL TOLERANCE	UNITS	mm	KLS P/N:	L-KLS1-GPS-YY04-RG174-L3M
.x ±0.30	SHEET SIZE	A4		
.xx ±0.20	Draw:	Song	2024-11-22	NingBo KLS ELECTRONIC CO.,L TD.
.xxx ±0.10	Check:	Daniel	2024-11-22	