

1
RoHS Compliance

REV	SYM	Revision Record	Appr.	Date
V0	KLS08011	New Version Release	Jenny	2024-11-26

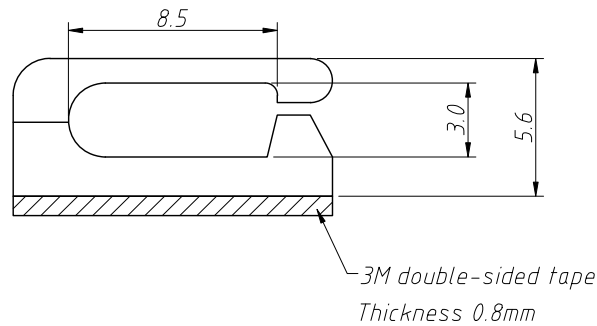
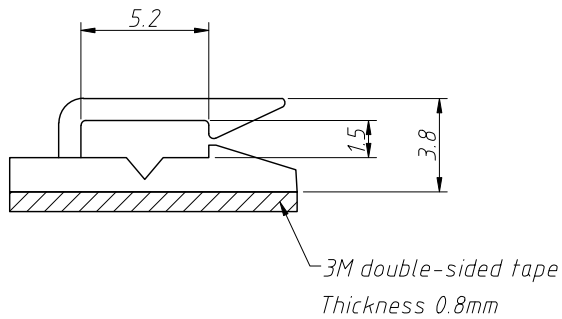
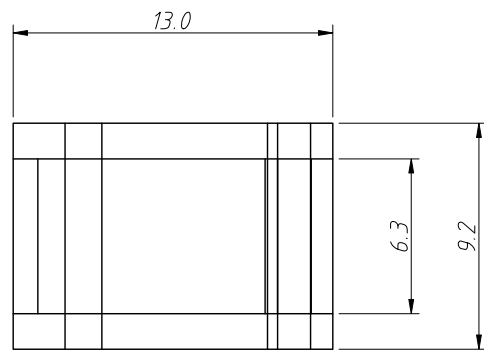
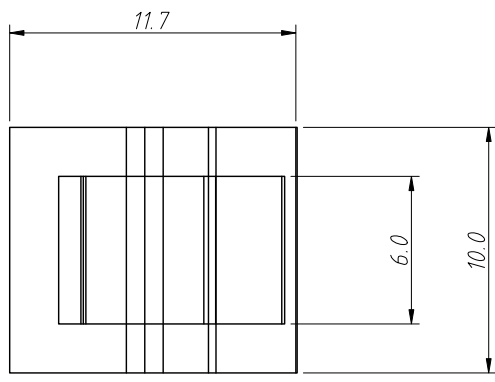

L-KLS8-0415-FC-1001

L-KLS8-0415-FC-1A

Material:PA66,UL94V-2,Natural
 Operating Temperature:0°C~+80°C
 Withstanding Voltage:2500V /0.5mA/1Sec
 Boiling water:Boil at 100°C to 110°C for 30minutes

The Appearance Shall Be Free Of Defects Such As Burrs, Burrs, Shrinkage, Etc
 This Product Does Not Contain Lead (Pb), Mercury (Hg), Pot (Cd), Hexavalent Inscription (Cr VI)
 The Material Used In This Product Has A Water Absorption Of 2.5% After 24 Hours Immersion At A Temperature Of 23 °C And A Relative Humidity Of 50%

ANGLE TOLERANCE	PROJECTION	Description:		
±3°		Self-Adhesive Wire Clip		
GENERAL TOLERANCE	UNITS	mm	KLS P/N:	L-KLS8-0415
x.x ±0.30	SHEET SIZE	A4		
x.xx ±0.20	Draw:	Jenny	2024-11-26	NingBo KLS ELECTRONIC CO.,L TD.
x.xxx ±0.10	Check:	Daniel	2024-11-26	