

1
RoHS Compliance

REV	SYM	Revision Record	Appr.	Date
V0	KLS02006	New Version Release	WuHao	2024-10-31

Electrical Characteristics	UL	IEC
Rated Voltage	300V	450V
Rated Current	15A	17.5A
Withstand Voltage	AC2000V/1 min	---
Wire Range	28~14 AWG	1.5mm ²

Material and other:
 Housing:PA66, UL94 V-0
 Clamp:Phosphor Bronze,Ni Plated
 Cage:Brass,Ni Plated
 Screw/Torque:Steel,M3,Zn Plated/0.5N.m
 Contact resistance:20mΩ MAX
 Insulation resistance:500MΩ/DC500V
 Stripping Length:7~8mm
 Temp.Range:-40°C~+105°C

Order Information
 L-KLS2-EDKB-7.50-XXP-X X

RoHS
 Terminal Block
 Pitch:7.50mm
 No. Of (02~24) Pin
 Color:1=Gray 2=Blue 3=Black
 4=Green 5=Orange 6=Red
 7=Transp 8=Yellow 9=White
 Screw:SC=Slot/Cross
 S-Slot Screw C-Cross Screw

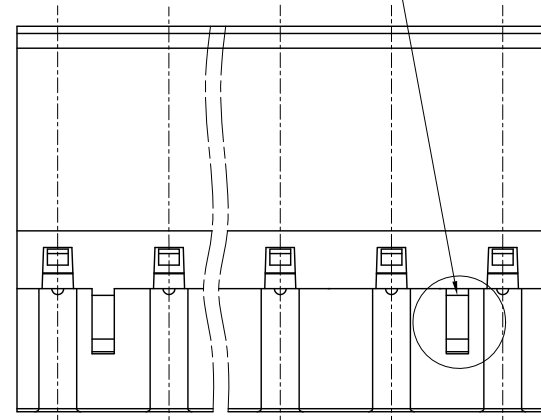
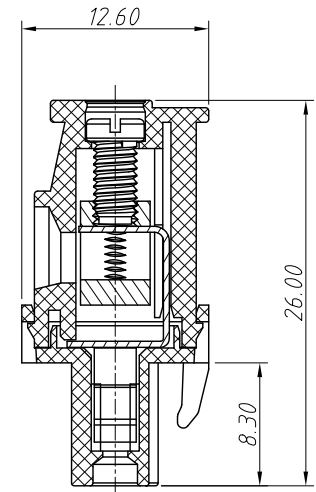
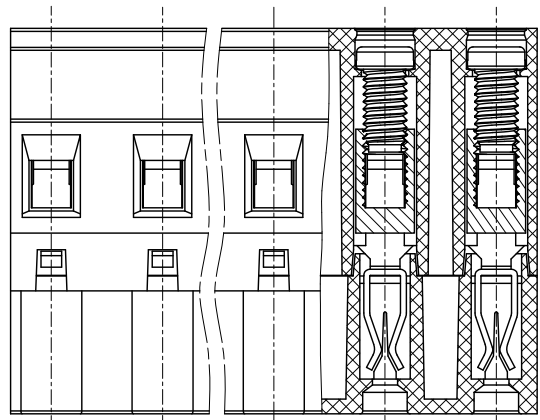
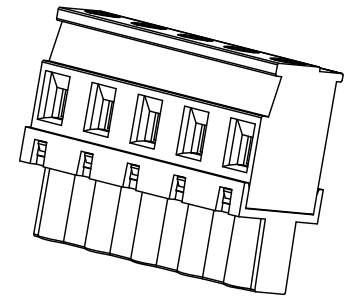
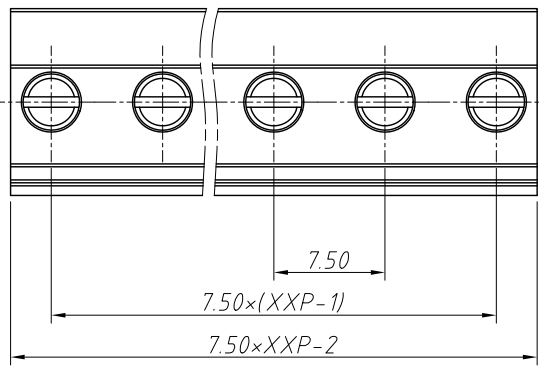
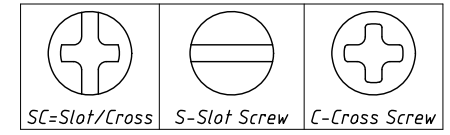

ANGLE TOLERANCE	PROJECTION	Description:
±3°		Pitch 7.50mm Terminal Block
GENERAL TOLERANCE	UNITS	mm
0~30 ±0.50	SHEET SIZE	A4
30~60 ±0.75	Draw:	WuHao 2024-10-31
60~90 ±1.00	Check:	Daniel 2024-10-31

1
RoHS Compliance

6	7	8
REV	SYM	Revision Record
V0	KLS02006	New Version Release
Appr.	WuHao	Date
		2024-10-31

Electrical Characteristics	UL	IEC
Rated Voltage	300V	320V
Rated Current	15A	20A
Withstand Voltage	AC2000V/1 min	---
Wire Range	28~14 AWG	1.5mm ²

Material and other:
 Housing:PA66, UL94 V-0
 Clamp:Phosphor Bronze,Ni Plated
 Cage:Brass,Ni Plated
 Screw/Torque:Steel,M3,Zn Plated/0.5N.m
 Contact resistance:20mΩ MAX
 Insulation resistance:500MΩ/DC500V
 Stripping Length:7~8mm
 Temp.Range:-40°C~+105°C

Order Information
 L-KLS2-EDKB-7.62-XXP-X X

RoHS
 Terminal Block
 Pitch:7.62mm
 No.:Of (02~24) Pin
 Color:1=Gray 2=Blue 3=Black
 4=Green 5=Orange 6=Red
 7=Transp 8=Yellow 9=White
 Screw:SC=Slot/Cross
 S-Slot Screw C-Cross Screw

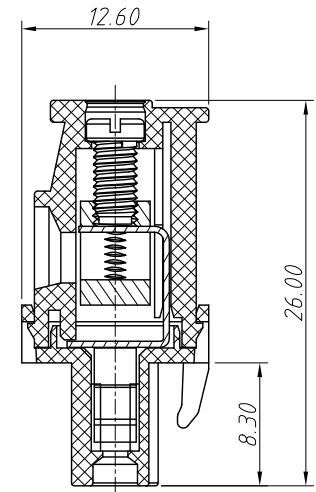
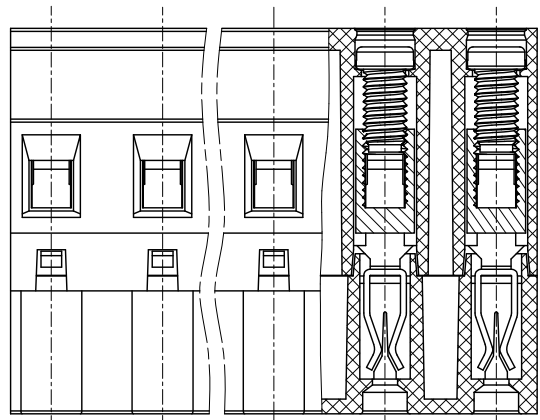
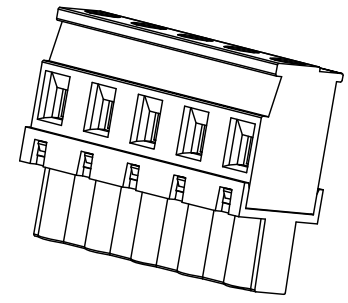
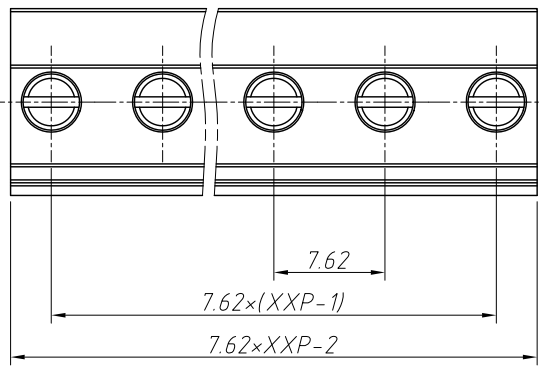
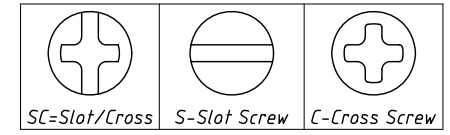

2P only has this card hook

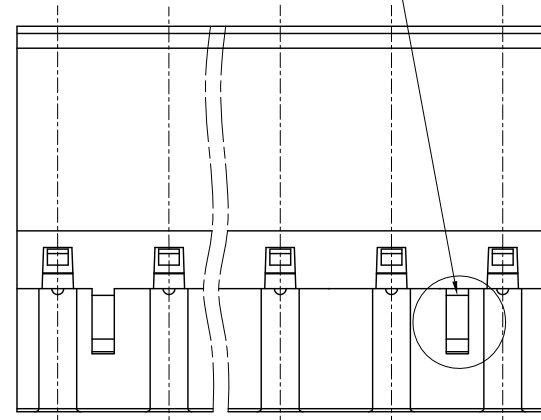

ANGLE TOLERANCE	PROJECTION	Description:
±3°		Pitch 7.62mm Terminal Block
GENERAL TOLERANCE	UNITS	mm
0~30 ±0.50	SHEET SIZE	A4
30~60 ±0.75	Draw:	WuHao 2024-10-31
60~90 ±1.00	Check:	Daniel 2024-10-31
		L-KLS2-EDKB-7.62-XXP-XX
		NingBo KLS ELECTRONIC CO.,L TD.