

1  
RoHS Compliance

6	7	8
REV	SYM	Revision Record
V0	KLS08011	New Version Release
		Appr. Song
		Date 2024-09-10

- Notes:
1. Material: PA66, UL 94V-2, Natural
  2. Operating Temperature: 0°C ~ +80°C
  3. The Appearance Shall Be Free Of Defects Such As Burrs, Shrinkage, Etc
  4. This Product Does Not Contain Lead (Pb), Mercury (Hg), Pot (Cd), Hexavalent Inscrption (Cr VI)
  5. The Material Used In This Product Has A Water Absorption Of 2.5% After 24 Hours Immersion At A Temperature Of 23 °C And A Relative Humidity Of 50%
  6. Boil water at 100°C ~ 110°C for 10 minutes

Item No:	A	PCB	
		HOLE	Thickness
L-KLS8-0208-CS-05	5.0	φ4.0	0.5 ~ 2.0
L-KLS8-0208-CS-10	9.6	φ4.0	0.5 ~ 2.0
L-KLS8-0208-CS-13	12.7	φ4.0	0.5 ~ 2.0
L-KLS8-0208-CS-19	19.1	φ4.0	0.5 ~ 2.0
L-KLS8-0208-CS-28	28.5	φ4.0	0.5 ~ 2.0
L-KLS8-0208-CS-35	35.0	φ4.0	0.5 ~ 2.0

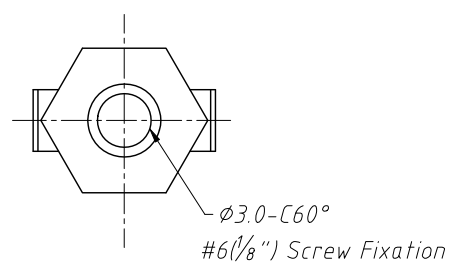
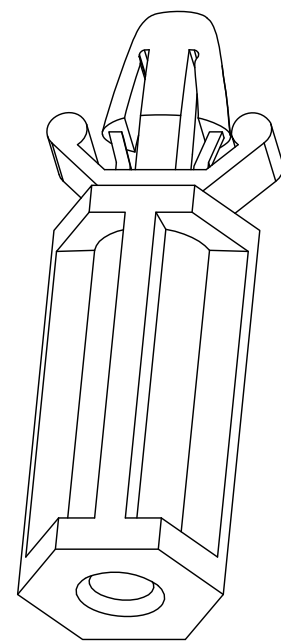
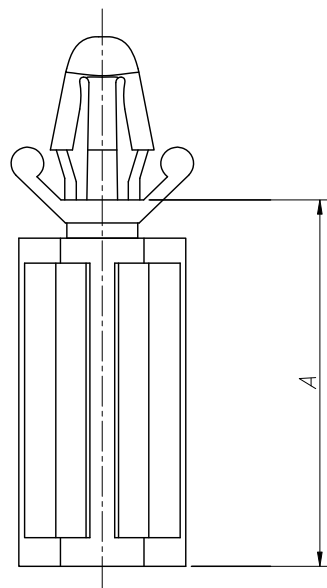
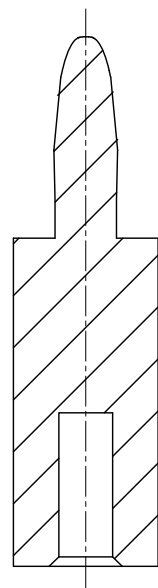

Unmarked	0 ~ 4	4 ~ 15	15 ~ 30	30 ~ 50	50 ~ 100	100 ~
Tolerance	±0.15	±0.2	±0.3	±0.5	±0.7	±1.0

ANGLE TOLERANCE	PROJECTION	Description:	Spacer Support			
±3°						
GENERAL TOLERANCE	UNITS	mm	KLS P/N:	L-KLS8-0208-CS-XX		
	SHEET SIZE	A4				
	Draw:	Song	2024-09-10		NingBo KLS ELECTRONIC CO.,L TD.	
	Check:	Daniel	2024-09-10			