

1 RoHS Compliance

REV	SYM	Revision Record	Appr.	Date
V0	KLS01640	New Version Release	Song	2024-07-01

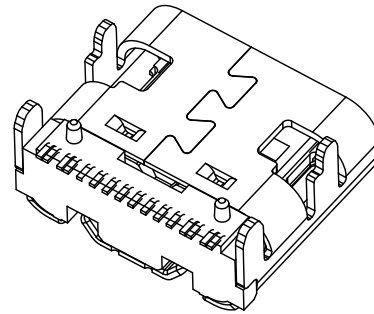
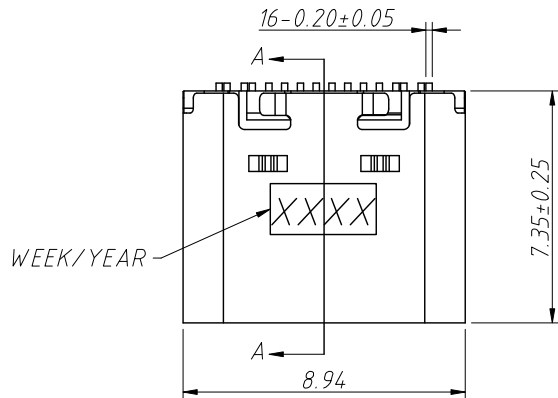

Order Information

L-KLS1-5416-L1-01-R

RoHS  
 USB Type  
 Length:  
 L1=0.96(H1=0.90)  
 L2=2.3(H2=2.0)  
 Plating Code:  
 01=AU 1u" 03=AU 3u"  
 15=AU 15u" 30=AU 30u"  
 Packing:R=Reel

NOTES:

1.Material:

- 1-1.Housing:High Temperature Resistant Plastic,UL94 V-0.
- 1-2.Contacts:Copper Alloy(C18150)
- 1-3.Mid Plate:Stainless Steel(SUS301)
- 1-4.Front Shell:Stainless Steel(SUS304)

2.Plating Specification:

- 2-1.Contacts:Ni 50u" Min.Under Plated Over All  
 Au Plated On The Functional Area Of Contact  
 Au Plated On The Solder Area
- 2-2.Front Shell:Ni 30u"Min.Under Plated Over All.
- 2-3.Mid Plate:Clear Only

3.Mechanical:

- 3-1.Insertion Force:0.5~2.0kgf
- 3-2.Removal Force:0.8kgf~2.0kgf
- 3-3.Durability:10000 Cycles

4.Electrical:

- 4-1. Voltage Rating:5 V DC/AC (RMS. Max)  
 Current Rating:5 AMPS. For Total VBUS/GND Pins  
 1.25AMPS For CC Pin,0.25 AMPS. For All Other Contact
- 4-2.LLCR:Vbus & GND Pins And Other Pins:40mΩ/Pin Max  
 LLCR Max.Change Of All Pins:10mΩ
- 4-3.Insulation Resistance:100MΩ Min
- 4-4.Dielectric Withstand Voltage:AC 100V For 1 Minute

5.Operating Temperature: -25°C ~ +85°C

6.IR Reflow:The Peak Temperature On The Board Shall Be Maintained For 10 Seconds At 260°C

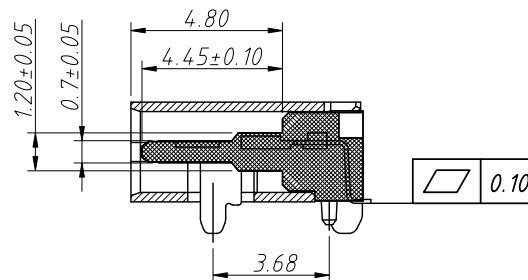
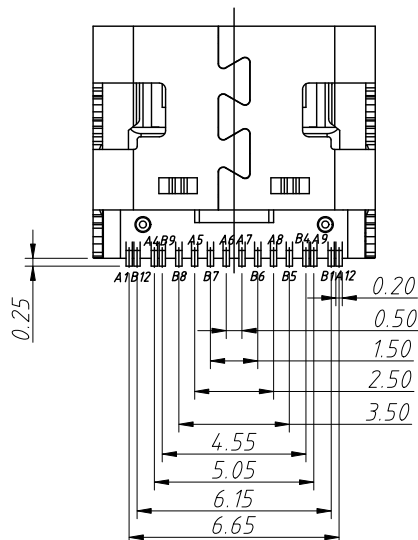
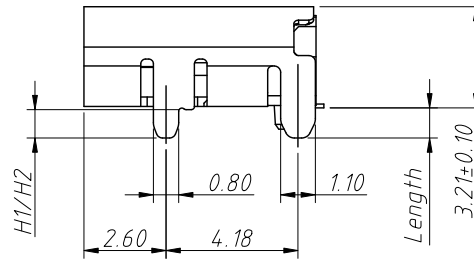
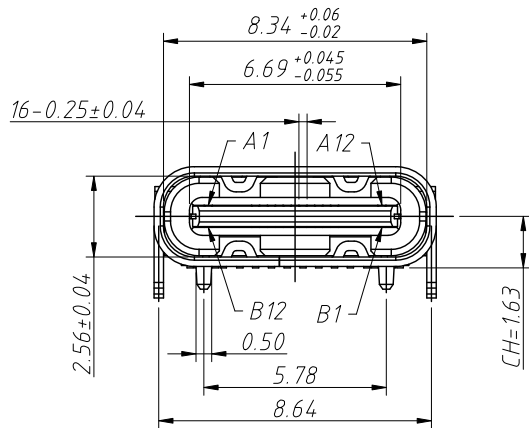

ANGLE TOLERANCE	PROJECTION	Description:	USB Connector	
±3°			L-KLS1-5416-LX-XX-R	
GENERAL TOLERANCE	UNITS	mm	KLS P/N:	
.x ±0.30	SHEET SIZE	A4	1 of 3	
.xx ±0.20	Draw:	Song	2024-07-01	
.xxx ±0.10	Check:	Daniel	2024-07-01	

NingBo KLS ELECTRONIC CO.,LTD.

1 RoHS Compliance

REV	SYM	Revision Record	Appr.	Date
V0	KLS01640	New Version Release	Song	2024-07-01

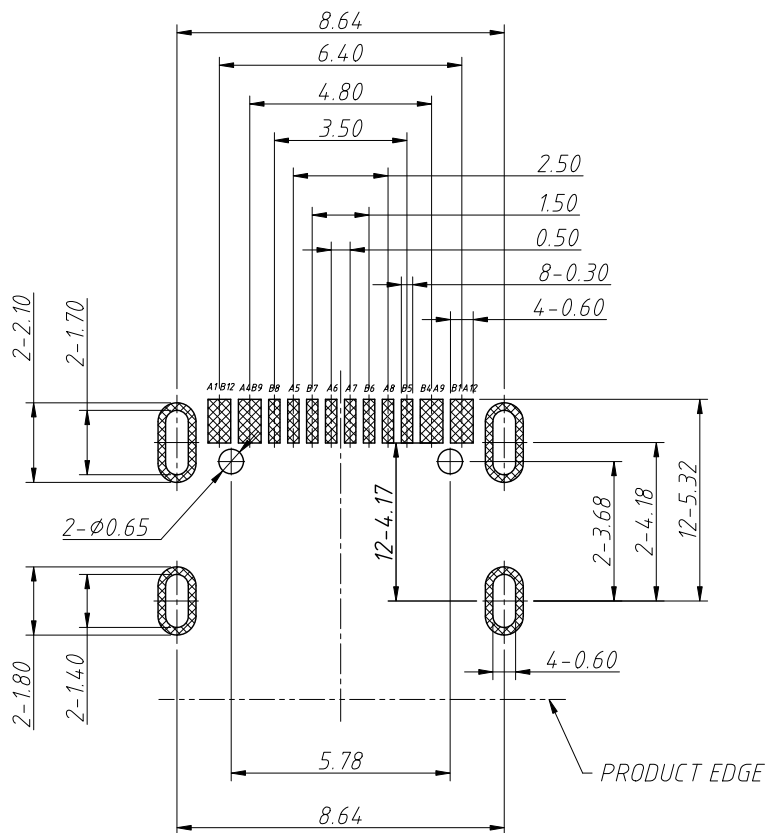

Recommended PCB Layout  
Tolerance: ±0.05mm, T=0.80

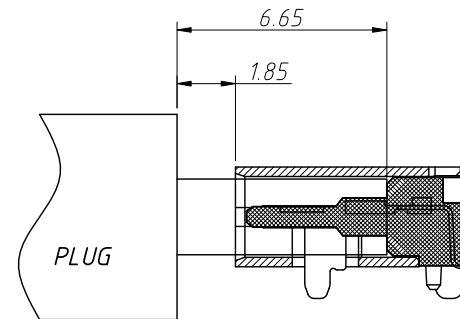

AFTER MATING

USB TYPE-C Pin Assignments

PIN	Signal Name	PIN	Signal Name
A1	GND	B12	GND
A4	VBUS	B9	VBUS
A5	CC1	B8	SBU2
A6	DP1	B7	DN2
A7	DN1	B6	DP2
A8	SBU1	B5	CC2
A9	VBUS	B4	VBUS
A12	GND	B1	GND

ANGLE TOLERANCE	PROJECTION	Description:	USB Connector
±3°			
GENERAL TOLERANCE	UNITS	mm	L-KLS1-54.16-LX-XX-R
.x ±0.30	SHEET SIZE	A4	
.xx ±0.20	Draw:	Song	NingBo KLS ELECTRONIC CO.,LTD.
.xxx ±0.10	Check:	Daniel	



NingBo KLS ELECTRONIC CO.,LTD.

1 RoHS Compliance

REV	SYM	Revision Record	Appr.	Date
V0	KLS01640	New Version Release	Song	2024-07-01

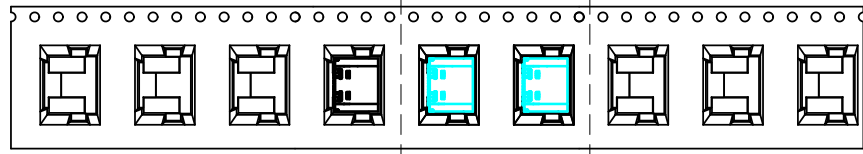

SEE DETAIL X

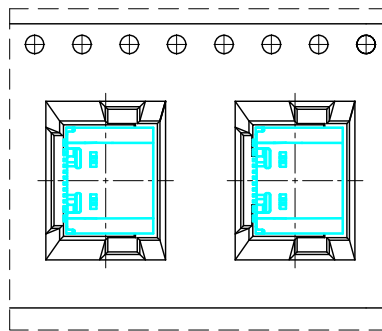
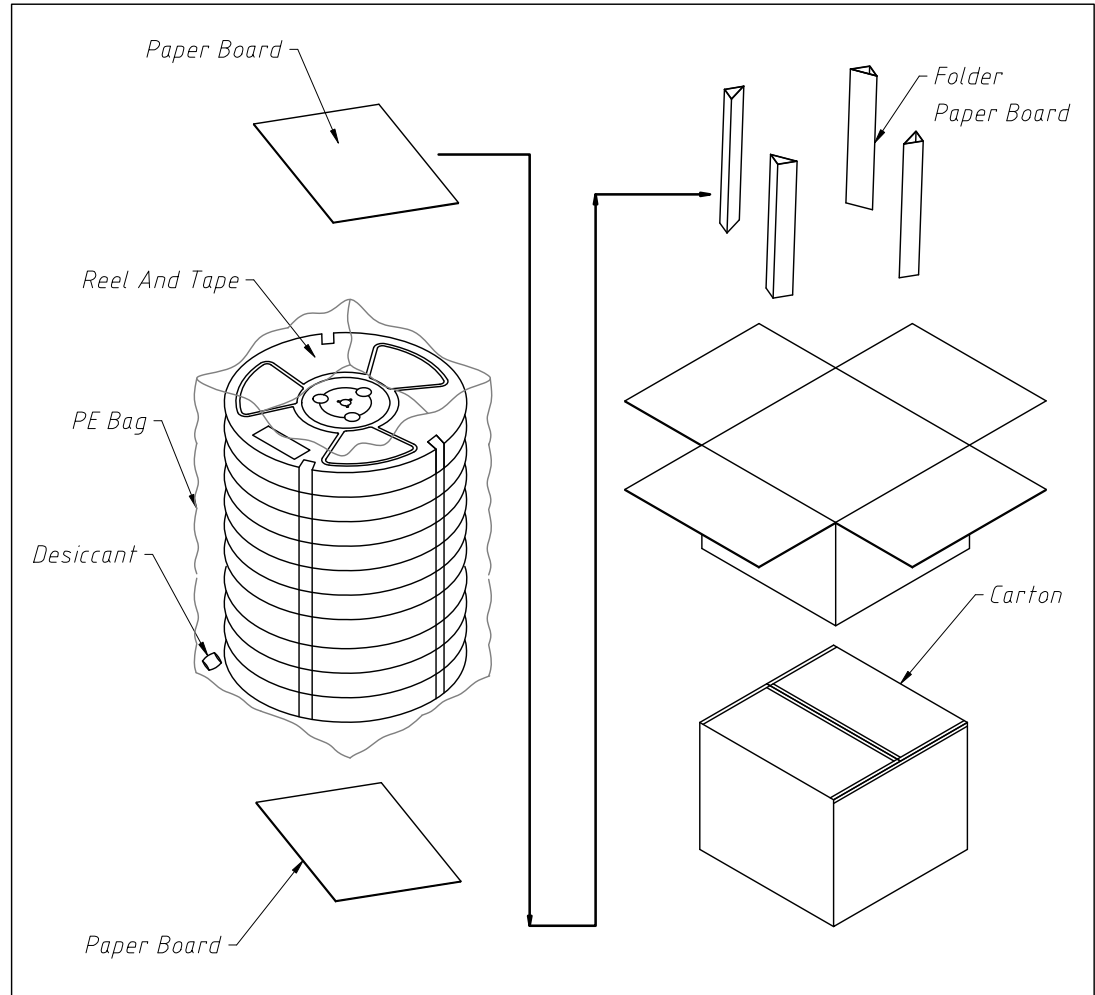
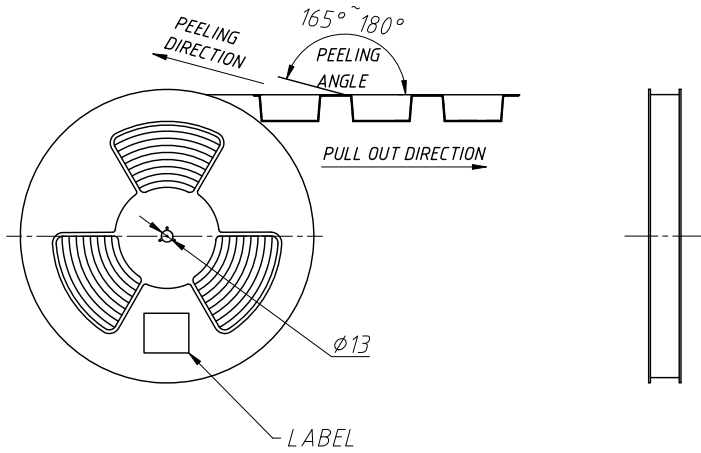

DETAIL X

ANGLE TOLERANCE	PROJECTION	Description:	USB Connector	
$\pm 3^\circ$				
GENERAL TOLERANCE	UNITS	mm	KLS P/N:	L-KLS1-54.16-LX-XX-R
.x $\pm 0.30$	SHEET SIZE	A4	3 Of 3	NingBo KLS ELECTRONIC CO.,LTD.
.xx $\pm 0.20$	Draw:	Song	2024-07-01	
.xxx $\pm 0.10$	Check:	Daniel	2024-07-01	