

1
RoHS Compliance

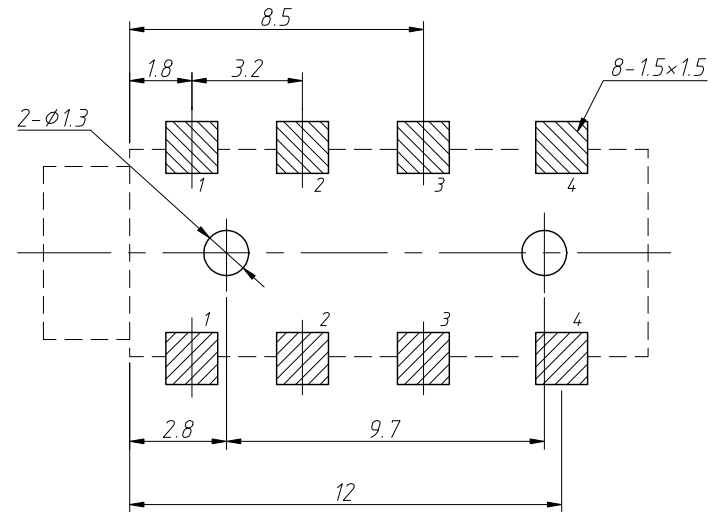

Schematic

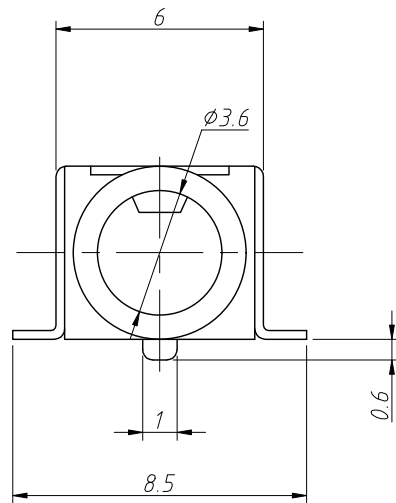
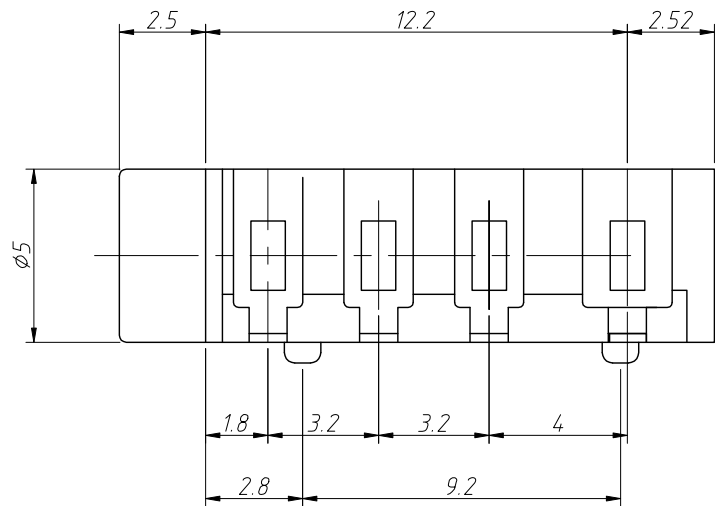
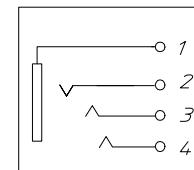

Notes:

1.Material:

Spring Piece:C5191,Ag-Plating

Housing:PPA

2.Electric:

Rating:DC 30V 0.5A

Contact Resistance:0.03Ω Max

Insulation Resistance:100MΩ Min(DC250V)

Withstand Voltage:500VAC

Insertion And Extraction Force:3~20N

Life Test:5,000 Cycles

ANGLE TOLERANCE	PROJECTION		Description:	3.5mm Phone Jack Connectors
±3°				
GENERAL TOLERANCE	UNITS	mm	KLS P/N:	L-KLS1-SPJ3.5-013
x.x ±0.30	SHEET SIZE	A4	XX	NingBo KLS ELECTRONIC CO.,L TD.
x.xx ±0.20	Draw:	Daniel	2023-07-17	
x.xxx ±0.10	Check:	Daniel	2023-07-17	