

1 RoHS Compliance

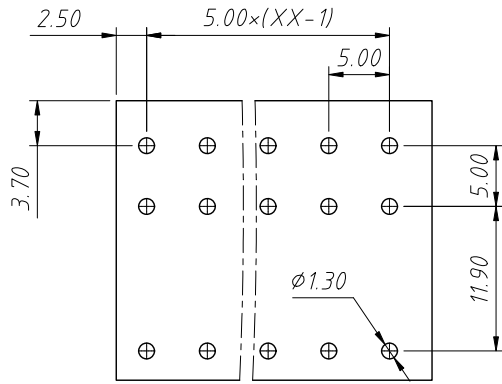

PCB LAYOUT

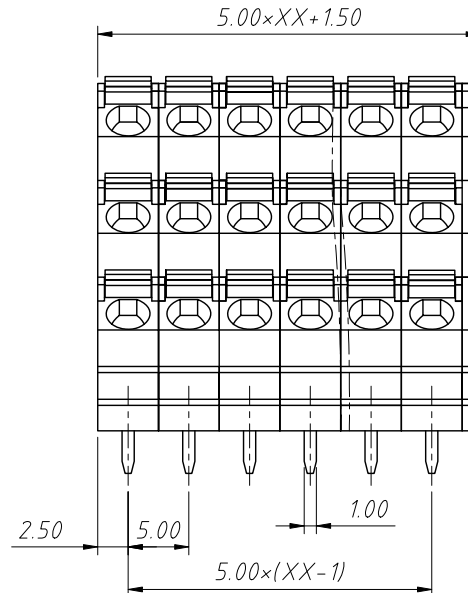
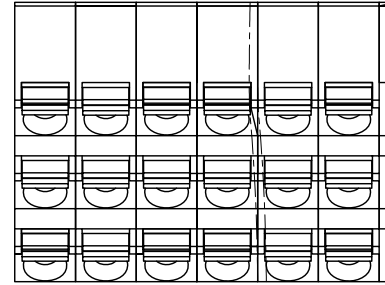
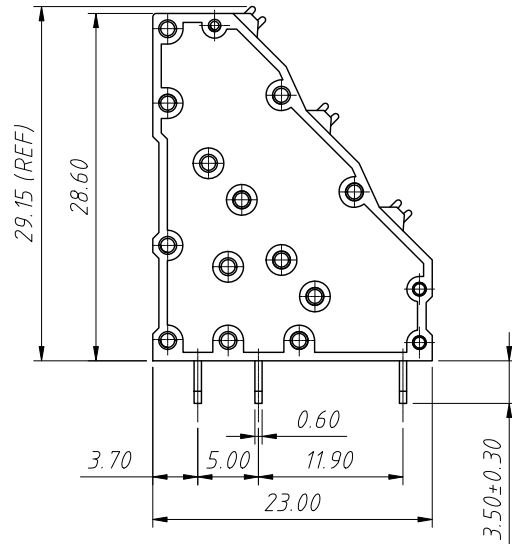

Material:
 Insulation: PA66, UL 94 V-0
 Contactor: Copper alloy, Sn plated

Electrical:
 Rated Voltage: 300V
 Rated Current: 10A
 Withstanding Voltage: 1600VAC (1min)

Mechanical:
 Wire Range: 16-28AWG
 Stripping Length: 8-9mm
 Operating temperature: -40°C to +105°C

Order Information:
 L-KLS2-252T3-5.00-XXP-X

L: RoHS
 Terminal Block
 Pitch: 5.00mm
 No.: of 3x01 ~ 3x24 Pole
 Color:
 1=Gray 2=Blue 3=Black
 4=Green 5=Orange 6=Red
 7=Transp 8=Yellow 9=White

ANGLE TOLERANCE	PROJECTION	Description:	5.00mm PCB Spring Terminal Block	
±3°				
GENERAL TOLERANCE	UNITS	mm	KLS P/N:	L-KLS2-252T3-5.00-XXP-X
x.x ±0.30	SHEET SIZE	A4		
x.xx ±0.20	Draw:	Daniel	2023-05-05	NingBo KLS ELECTRONIC CO.,LTD.
x.xxx ±0.10	Check:	Daniel	2023-05-05	