

1 RoHS Compliance

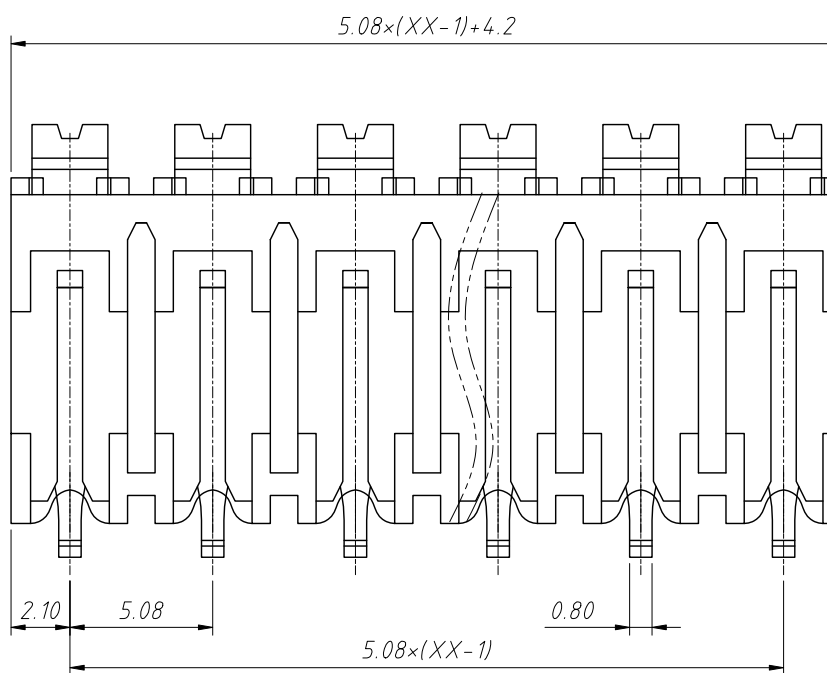
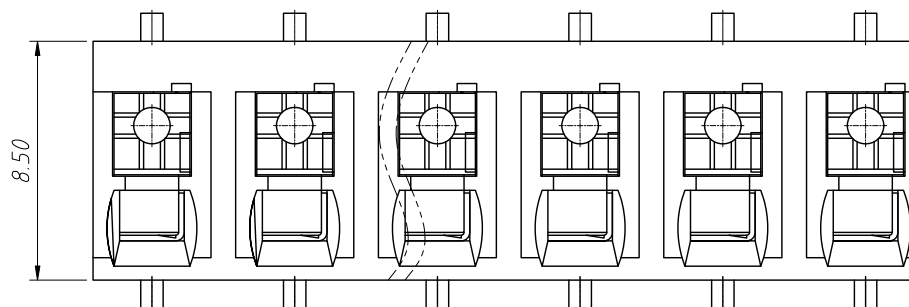
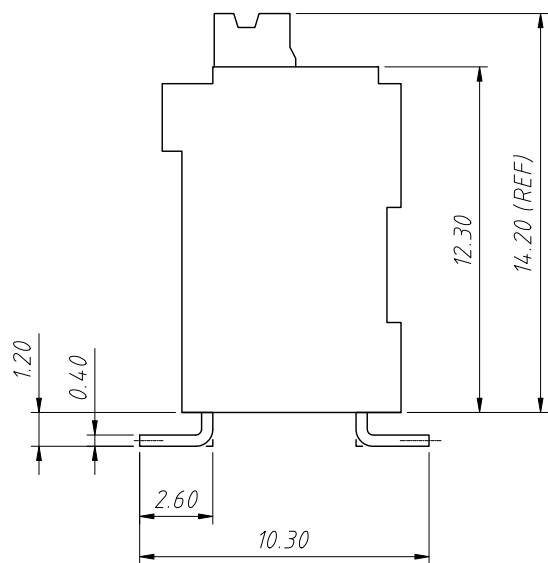
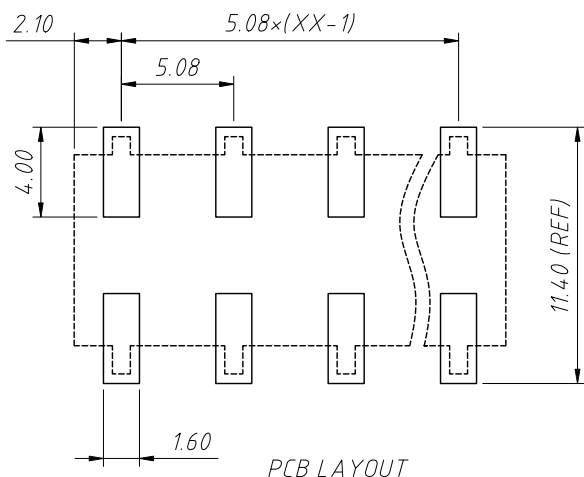

Material:
 Insulation:LCP,UL 94V-0
 Contactor:Copper alloy,Sn plated

Electrical:
 Rated Voltage:300V
 Rated Current:10A
 Withstanding Voltage:1600VAC(1min)

Mechanical:
 Wire Range:16-24AWG
 Stripping Length:7-8mm
 Pin Dimensions:0.8×0.4mm
 Operating temperature:-40°C to +130°C

Order Information:
 L-KLS2-212VS-5.08-XXP-X

L: RoHS
 Terminal Block
 Pitch:5.08mm
 No.: of 02 ~ 24 Pole
 Color:
 1=Gray 2=Blue 3=Black
 4=Green 5=Orange 6=Red
 7=Transp 8=Yellow 9=White

ANGLE TOLERANCE	PROJECTION	Description:	
±3°		5.08mm PCB Spring Terminal Block	
GENERAL TOLERANCE	UNITS	mm	KLS P/N:
x.x ±0.30	SHEET SIZE	A4	L-KLS2-212VS-5.08-XXP-X
x.xx ±0.20	Draw:	Daniel	2023-05-05
x.xxx ±0.10	Check:	Daniel	2023-05-05

NingBo KLS ELECTRONIC CO.,L.TD.