

Plastic square shape photoelectric sensors **PTF** series

Features

- ◆ Diffuse reflection working principle;
- ◆ Excellent anti-interference performance
- ◆ High detection accuracy

Part number

NPN NO	PTF-BC50DNO-E2	PTF-BC100DNO-E2	PNP NO	PTF-BC50DPO-E2	PTF-BC100DPO-E2
NPNNC	PTF-BC50DNC-E2	PTF-BC100DNC-E2	PNP NC	PTF-BC50DPC-E2	PTF-BC100DPC-E2
NPN NO+NC	PTF-BC50DNR-E2	PTF-BC100DNR-E2	PNP NO+NC	PTF-BC50DPR-E2	PTF-BC100DPR-E2

Technical specifications

Detection type	Diffuse reflection	Consumption current	≤25mA
Rated distance [Sn]	50cm(adjustable)100cm (adjustable)	Circuit protection	Short-circuit, overload and reverse polarity
Standard target	White card reflection rate 90%	Response time	< 8.2ms
Light source	Infrared LED (880nm)	Output indicator	Power: Green LED Output: Yellow LED
Dimensions	50 mm *50 mm *17mm	Ambient temperature	-15°C...+55°C
Output	NO/NC (depends on part No.)	Ambient humidity	35-85%RH (non-condensing)
Supply voltage	10...30 VDC	Voltage withstand	1000V/AC 50/60Hz 60s
Target	Opaque object	Insulation resistance	≥50MΩ(500VDC)
Hysteresis range [%/Sr]	3...20%	Vibration resistance	10...50Hz (0.5mm)
Repeat accuracy [R]	≤5%	Degree of protection	IP64
Load current	≤200mA	Housing material	PC/ABS
Residual voltage	≤2.5V	Connection type	M12 Connector

Dimensions

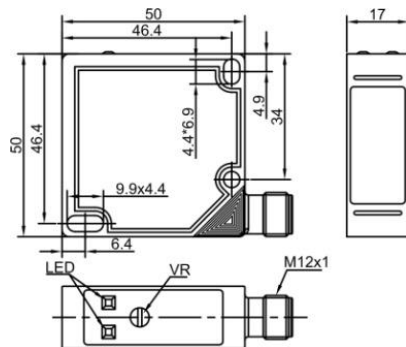

Wiring diagram

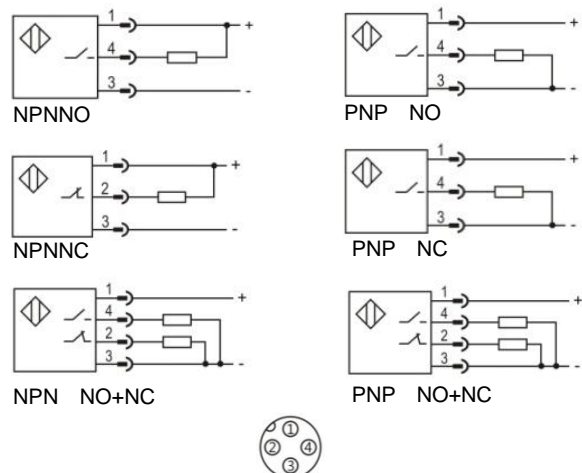

Plastic square shape photoelectric sensors PTF series



Features

- ◆ Diffuse reflection working principle;
- ◆ Excellent anti-interference performance
- ◆ High detection accuracy

Part number

NPN NO	PTF-BC50DNO	PTF-BC100DNO	PNP NO	PTF-BC50DPO	PTF-BC100DPO
NPNC	PTF-BC50DNC	PTF-BC100DNC	PNP NC	PTF-BC50DPC	PTF-BC100DPC
NPN NO+NC	PTF-BC50DNR	PTF-BC100DNR	PNP NO+NC	PTF-BC50DPR	PTF-BC100DPR

Technical specifications

Detection type	Diffuse reflection	Consumption current	≤25mA
Rated distance [Sn]	50cm(adjustable)100cm (adjustable)	Circuit protection	Short-circuit, overload and reverse polarity
Standard target	White card reflection rate 90%	Response time	< 8.2ms
Light source	Infrared LED (880nm)	Output indicator	Power: Green LED Output: Yellow LED
Dimensions	50 mm *50 mm *17mm	Ambient temperature	-15°C...+55°C
Output	NO/NC (depends on part No.)	Ambient humidity	35-85%RH (non-condensing)
Supply voltage	10...30 VDC	Voltage withstand	1000V/AC 50/60Hz 60s
Target	Opaque object	Insulation resistance	≥50MΩ(500VDC)
Hysteresis range [%/Sr]	3...20%	Vibration resistance	10...50Hz (0.5mm)
Repeat accuracy [R]	≤5%	Degree of protection	IP64
Load current	≤200mA	Housing material	PC/ABS
Residual voltage	≤2.5V	Connection type	2m PVC cable

Dimensions

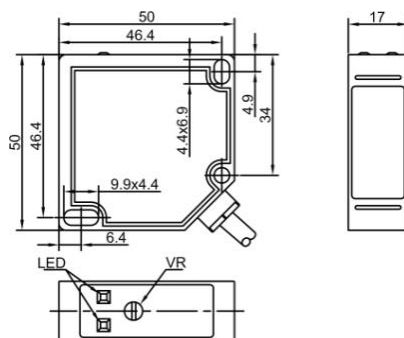

Wiring diagram

