

Plastic square shape photoelectric sensors **PTL** series

Features

- ◆ Polarized reflection working principle;
- ◆ Suitable for detecting transparent or high reflective target;
- ◆ High detection accuracy

Part number

NPN NO+NC	PTL-PM12DNR-D	PNP NO+NC	PTL-PM12DPR-D
-----------	---------------	-----------	---------------

Technical specifications

Detection type	Polarized reflection	Consumption current	≤25mA
Rated distance [Sn]	12m (non-adjustable)	Circuit protection	Short-circuit, overload and reverse polarity
Standard target	TD-05 reflector	Response time	< 8.2ms
Light source	Red LED (650nm)	Output indicator	Yellow LED
Dimensions	88mm*65mm*25mm	Ambient temperature	-15°C...+55°C
Output	NPNNO+NC PNP NO+NC	Ambient humidity	35-85%RH (non-condensing)
Supply voltage	10...30 VDC	Voltage withstand	1000V/AC 50/60Hz 60s
Target	Transparent, semi-transparent, Opaque object	Insulation resistance	≥50MΩ(500VDC)
Repeat accuracy [R]	≤5%	Vibration resistance	10...50Hz (0.5mm)
Load current	≤200mA	Degree of protection	IP67
Residual voltage	≤2.5V	Housing material	PC/ABS
		Connection type	Terminal

Dimensions

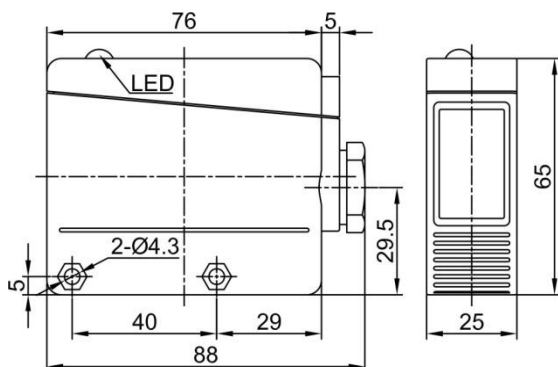

Wiring diagram

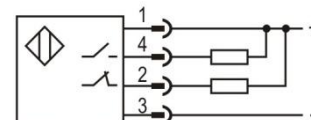

NPN NO+NC

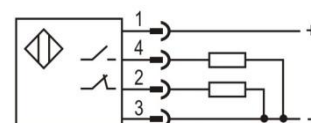

PNP NO+NC