

1
RoHS Compliance

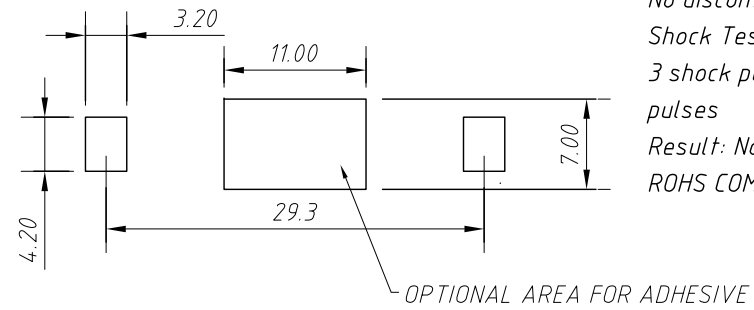

PCB LAYOUT

SPECIFICATIONS:
 Holder material- 30% glass reinforced Liquid Crystal Polymer resin, UL94V-0
 Color: off White
 Contacts : 0.020" thick PHOS-BRONZE, GOLD FLASH
 Temperature range: -40°C to +280°C
 Vibration Test: 10-50-10 Hz swept in 60 seconds
 X,Y,Z direction: 1 hour each direction
 Result: No dislodgement of the cell or damage
 No discontinuity over 10 micro-seconds
 Shock Test: Half sine wave acceleration 150G. 6 ms
 3 shock pulses each direction per axis, total of 18 pulses
 Result: No evidence of physical damage
 ROHS COMPLIANT

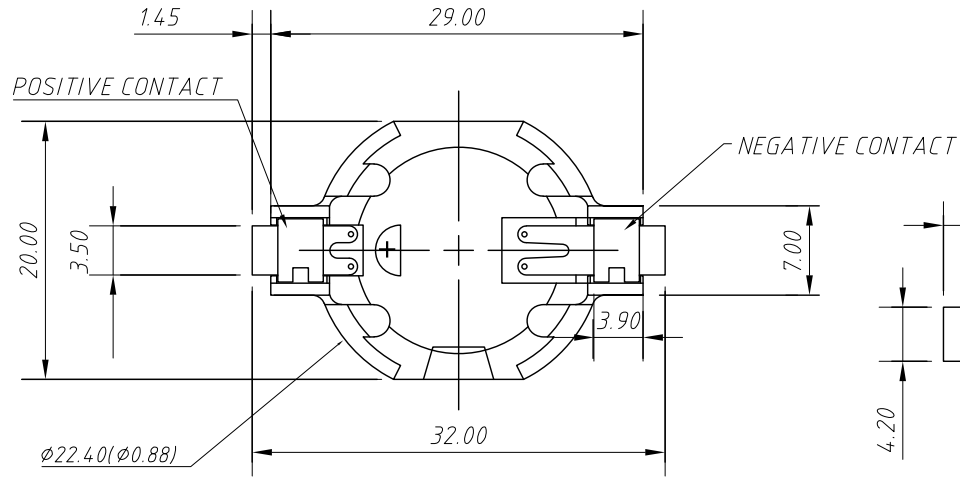
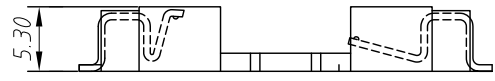

Order Information:
 L-KLS5-CR2032-62
 L: RoHS
 CR2032 Coin
 Battery Holder
 Part Number

ANGLE TOLERANCE		Description:	
±3°		CR2032 SMD COIN CELL RETAINERS, H5.30mm, Au plated, Reel	
GENERAL TOLERANCE	UNITS	mm	KLS P/N:
x.x ±0.30	SHEET SIZE	A4	L-KLS5-CR2032-62
x.xx ±0.20	Draw:	Daniel	2022-03-01
x.xxx ±0.10	Check:	Daniel	2022-03-01

