

RoHS Compliance

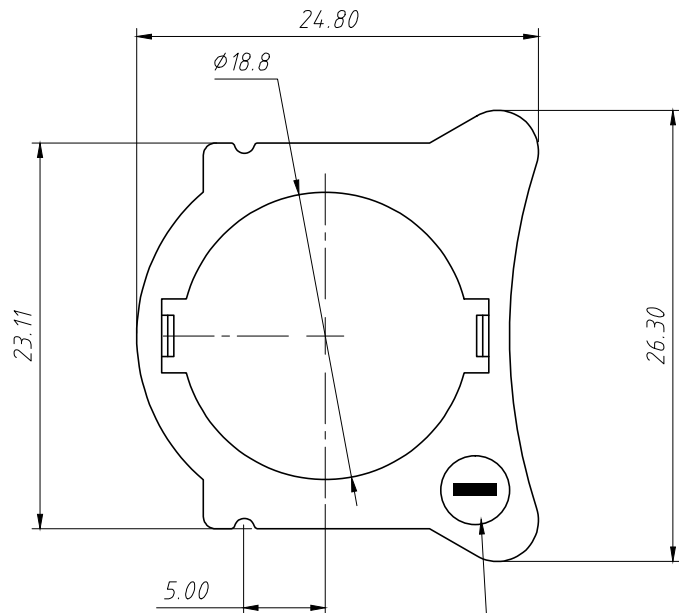

Negative Marking On Opposite Side

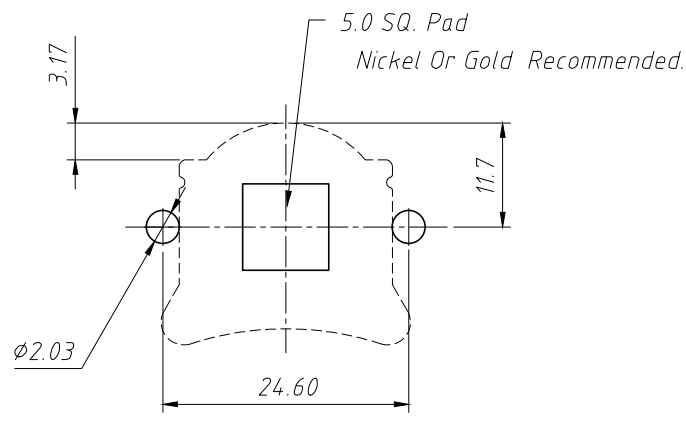
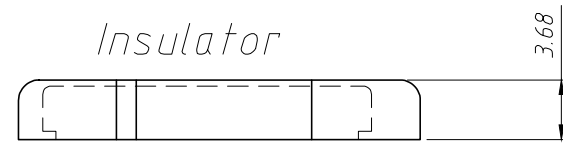
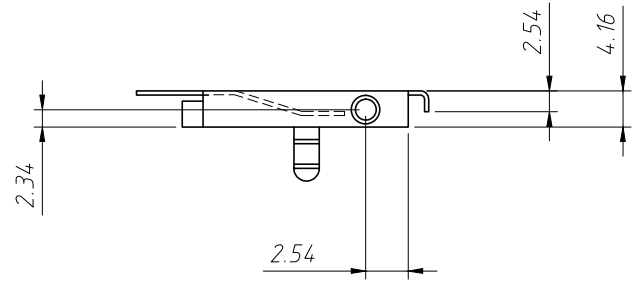
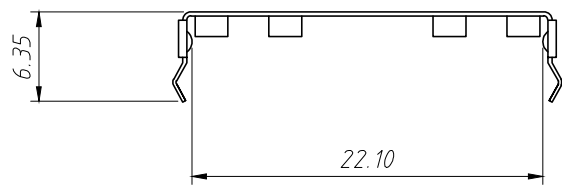
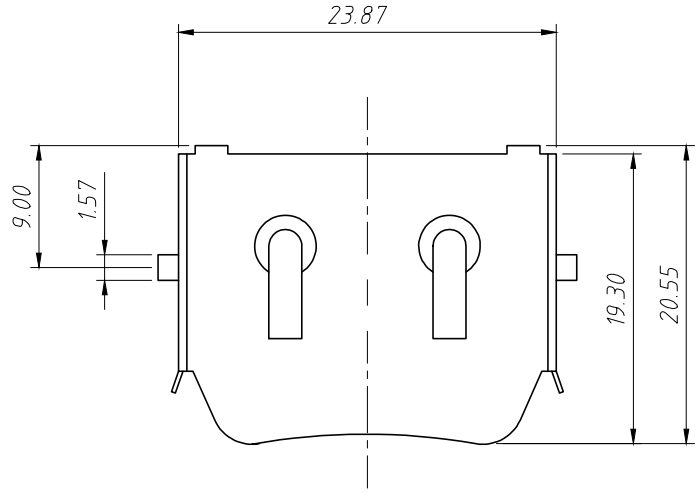

PCB Layout

Description:
 Material:
 Holder: Polypropylene, AV161 PP, Off White
 UL Flammability Rating: UL 94-HB File No. E108370
 Contacts : Phosphor Bronze C5191, Nickel
 Plated 80-150u Thickness
 Vibration Test: 10-50-10 HZ Swept In 60 Seconds
 X, Y, Z. Direction: 1 Hour Each Direction.
 Result: No Dislodgement Of The Cell Or Damage
 No Discontinuity Over 10 Milliseconds.
 Shock Test: Half Sine Wave Acceleration 150g.
 6 Milliseconds 3 Shock Pulses Each
 Direction Per Axis. Total Of 18 Pulses.
 Result: No Evidence Of Physical Damage.

ANGLE TOLERANCE	PROJECTION	Description:		
±3°		CR2032 Coin Cell Retainers		
GENERAL TOLERANCE	UNITS	mm	KLS P/N:	
0-6	±0.10	SHEET SIZE	A4	L-KLS5-CR2032-44B
6-30	±0.20	Draw:	Daniel	2023-02-23
30-120	±0.30	Check:	Daniel	2023-02-23

