

1 RoHS Compliance

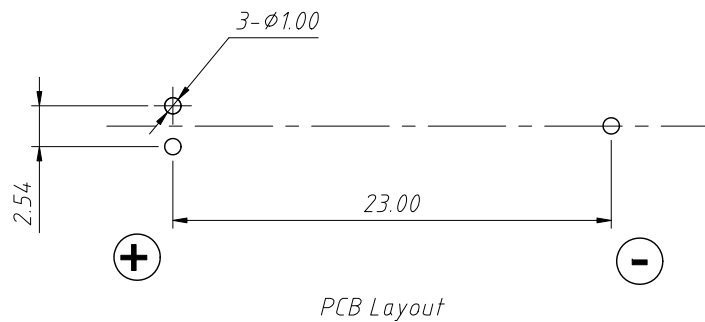
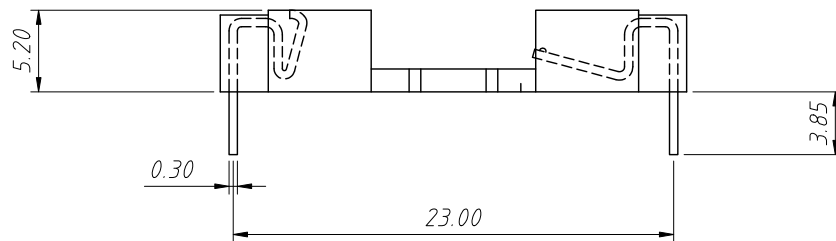
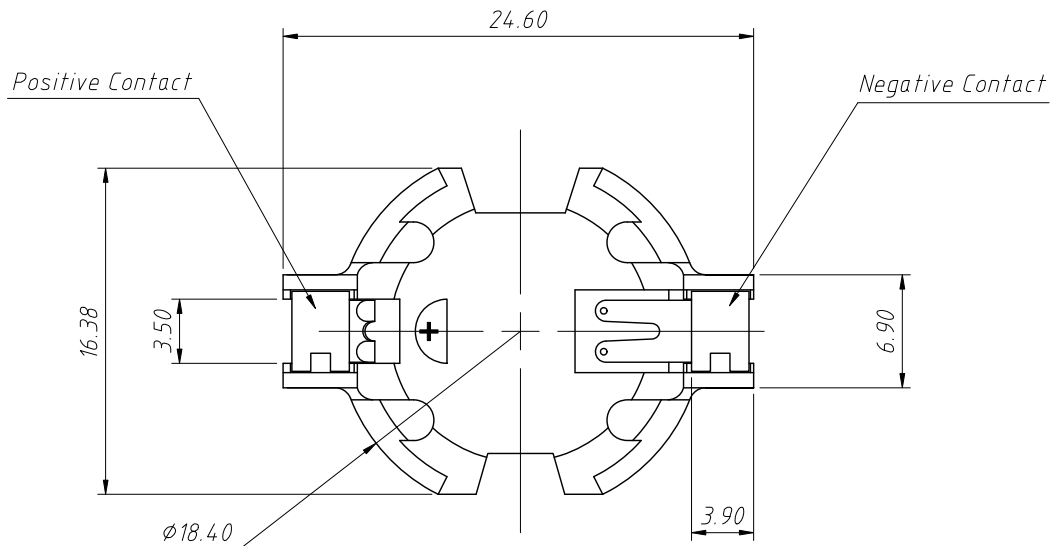

Specifications:

1. Holder material- Zenite 30% glass reinforced Liquid Crystal Polymer resin, UL File No. E344082, UL94V-0
2. Color: Off White
3. Contacts : 0.5mm thick Phos-Bronze, Gold Flash
4. Temperature range: -40°C to +280°C
5. Vibration Test: 10-50-10 Hz swept in 60 seconds
X,Y,Z direction: 1 hour each direction
6. Result: No dislodgement of the cell or damage
No discontinuity over 10 micro-seconds
7. Shock Test: Half sine wave acceleration 150G.
6 milli-seconds 3 shock pulses each direction per axis, total of 18 pulses
8. Result: No evidence of physical damage
9. Approximate weight: 0.92g
10. RoHS Compliant

Order Information:

L-KLS5-CR1632-05-A

L: RoHS

CR1632 Coin

Cell Retainers

Part Number

Packing: A-Bag

ANGLE TOLERANCE	PROJECTION	Description:	CR1632 SMD COIN CELL RETAINERS, H5.20mm, Tin plated
$\pm 3^\circ$			
GENERAL TOLERANCE	UNITS	mm	KLS P/N: L-KLS5-CR1632-05-A
x.x ± 0.30	SHEET SIZE	A4	
x.xx ± 0.20	Draw:	Daniel	2022-03-01
x.xxx ± 0.10	Check:	Daniel	2022-03-01



NingBo KLS ELECTRONIC CO.,L TD.