

1 RoHS Compliance

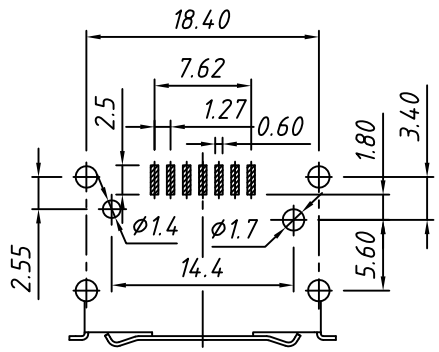
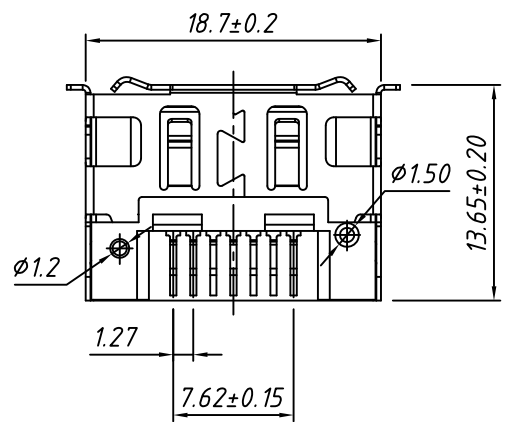
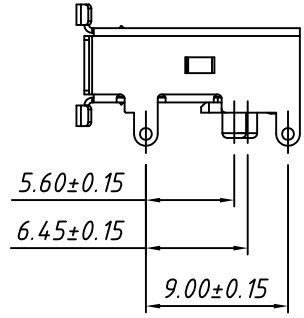
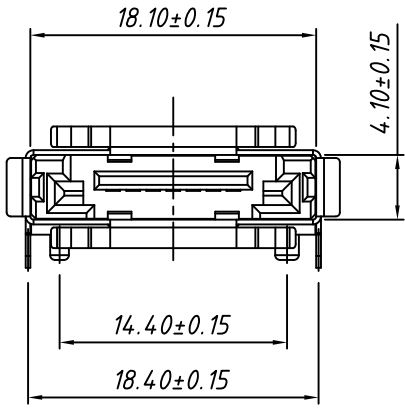

Recommend PC Board Layout

MATERIAL:
 Housing:LCP,UL 94-V0 ,Black
 Contact:Copper alloy,50u"min. Nickel plating
 Overall;100u" min.Tin on solder tail;
 Gold plating on contact area.
 PEG:Brass,Nickel and Tin plating overall.

ELECTRICAL:
 Contact Resistance: 25 mΩ Max.
 Insulation Resistance:1000 MΩ Min.
 Dielectric Withstanding Voltage: 500VRMS Min.

TOLERANCE	PROJECTION	UNITS	SHEET	Draw:	Date	Description:
.X ±0.30		mm	A4	Daniel	2018-03-01	e-SATA 7P Male Connector,SMD,DOWN PCB
.XX ±0.20				Daniel		
.XXX ±0.10						KLS P/N: L-KLS1-SATA502D
X. ±2°						NingBo KLS ELECTRONIC CO.,LTD.
.X ±1°						
.XX ±0.5°						

1 RoHS Compliance

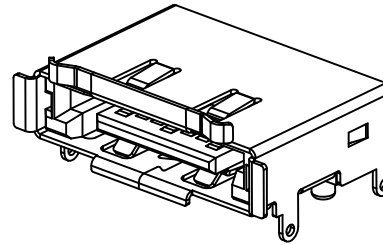
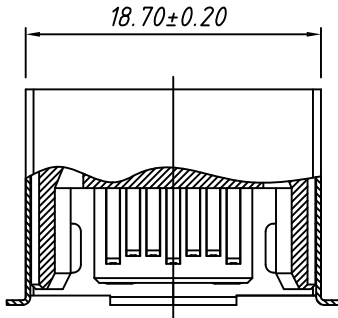

MATERIAL:

Housing:LCP,UL94-V0,Black
 Contact:Copper alloy,50u"min. Nickel plating
 Overall;100u" min.Tin on solder tail;
 Gold plating on contact area.
 PEG:Brass,Nickel and Tin plating overall.

ELECTRICAL:

Contact Resistance: 25 mΩ Max.
 Insulation Resistance:1000 MΩ Min.
 Dielectric Withstanding Voltage: 500VRMS Min.

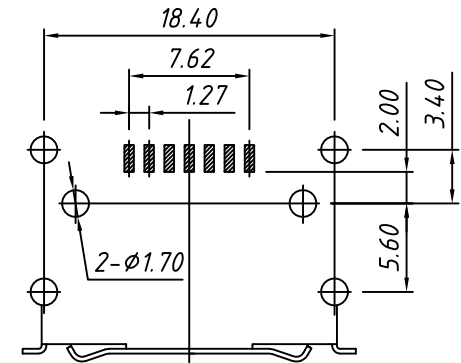
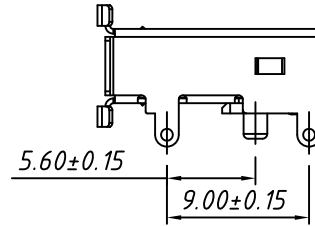
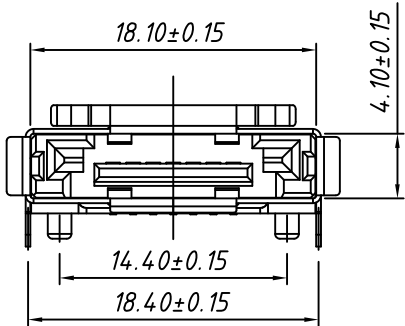

Recommend PC Board Layout

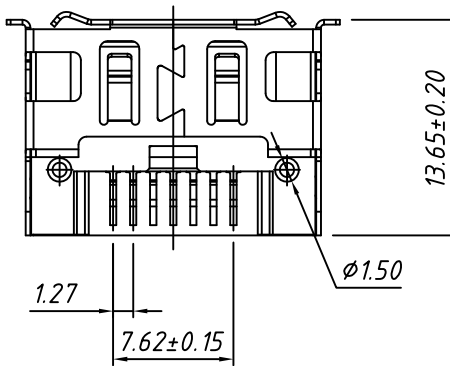

TOLERANCE	PROJECTION		Description:	
.X ±0.30	PROJECTION		e-SATA 7P Male Connector,SMD,UP PCB	
.XX ±0.20	UNITS	mm		
.XXX ±0.10	SHEET	A4	KLS P/N:	L-KLS1-SATA502U
X. ±2°	Draw:	Daniel		NingBo KLS ELECTRONIC CO.,LTD.
.X ±1°	Check:	Daniel		
.XX ±0.5°	Date	2018-03-01		